

PRECISION ROLLING BEARINGS



TUNG PEI INDUSTRIAL CO., LTD

CAT. NO. 2260/TE

Although care has been taken to assure the accuracy of the data compiled in this catalog, TPI does not assume any liability to any company or person for errors or omissions.

Contents

1. High Precision Bearing	
Structure and Arrangement.....	2
2. Bearing Number Codes	5
3. Bearing Tolerance and Fits	9
4. Bearing Load Rating and Life	15
5. Bearing Preload and Rigidity	17
6. Bearing Lubrication	23
7. Bearing Limiting Speed.....	26
8. Bearing Handling	28
■ TPI Products	30
■ Appendices	48

1. High Precision Bearing Structure and Arrangement

1.1 Bearing Arrangement for Main Spindles

Typical examples of bearing arrangements for main spindles of machine tools are summarized in Table 1.1. An optimal bearing arrangement must be determined through considerations

about the properties required of the main spindle in question (maximum speed, radial and axial rigidities, main spindle size, required accuracies, lubrication system, etc.). Recently, an increasing number of new machine tool models incorporate built-in motor type main spindles. However, heat generation on a built-in motor can affect the accuracy of the main spindle and performance of lubricant, so a main spindle bearing should be selected very carefully.

Table 1.1 Typical examples of bearing arrangements for main spindles

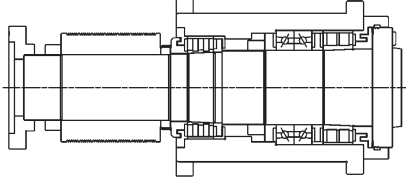
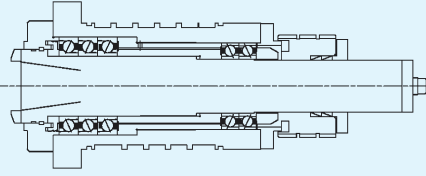
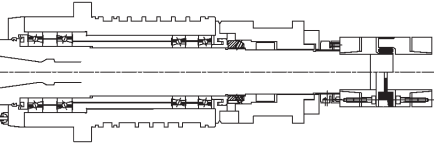
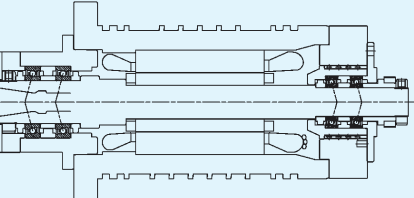
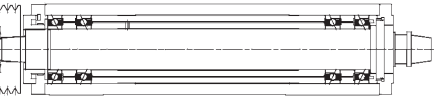
Type	Bearing arrangement for main spindle	Bearing type	Lubrication	Typical applications
1	 Belt-driven configuration	Double-row cylindrical roller bearing + High-speed duplex angular contact ball bearing for axial load (DB arrangement) + Double-row cylindrical roller bearing	Grease	CNC turning machine Machining center Milling machine
2	 Belt-driven configuration	Triple angular contact ball bearing (DT arrangement) + Duplex angular contact ball bearing (DT arrangement)	Grease	Machining center
3	 Direct-driven configuration	Duplex angular contact ball bearing (DT arrangement) + Duplex angular contact ball bearing (DT arrangement)	Grease	Machining center
4	 Built-in motor-driven configuration	Duplex angular contact ball bearing (DT arrangement) + Duplex angular contact ball bearing (DT arrangement)	Grease/ air Oil	Machining center Small turning machine Grinding machine
5	 Belt-driven configuration	Duplex angular contact ball bearing (DT arrangement) + Duplex angular contact ball bearing (DT arrangement)	Grease/ air Oil/ Oil mist	Grinding machine

1.2 Structure of Spindle Bearings

1.2.1 Duplex Arrangement Bearings

As Fig. 1.1 shows, angular contact ball bearings in duplex arrangements vary in combinations of two, three or four, in accordance to user's required specifications. Back-to-back duplex (DB) arrangement and face-to-face duplex (DF) arrangement can both sustain radial and axial loads in both directions. The wider distance between the effective load centers of the DB arrangement allows larger moment loads to be handled. The main spindle in machine tools often uses this arrangement.

Compared with the DB arrangement, the DF arrangement has shorter distance between the effective load centers, therefore the capacity to handle moment loads is small. However, it possesses greater allowable inclination angle than the DB arrangement.

The tandem duplex (DT) arrangement is able to handle both radial load and large axial load, but only in one direction. The four-row duplex (DTBT) arrangement is commonly used for the main spindles of machining centers because it offers high rigidity and accommodates high-speed operation.

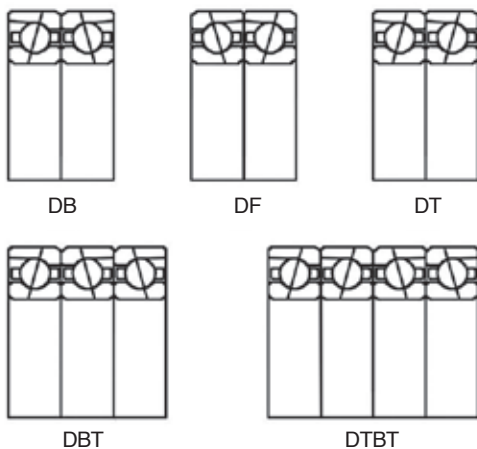

Fig.1.1 Duplex arrangement codes

1.2.2 Marking of Bearings and Bearing Sets

A “<” shaped marking on the outside surface of the outer rings of matched bearing sets indicates how the bearings should be mounted to obtain the proper preload in the set. The marking also indicates how the bearing set should be mounted in relation to the axial load. The “<” should point in the direction in which the axial load will act on the inner ring. In applications where there are axial loads in both directions, the “<”

should point toward the greater of the two loads, refer to Fig. 1.2 ◦

For universal combination bearings described in 1.2.3, the “<” marking on the outside surface of the outer rings shown in Fig. 1.3, prevent “direction” mistakes, ensure correct matching when they are mounted.

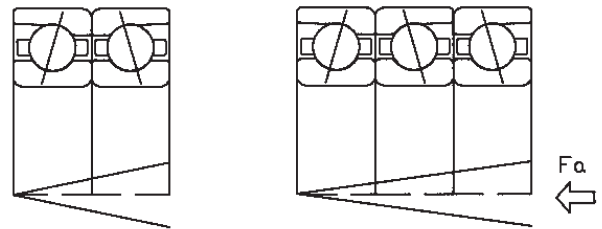

Fig.1.2. A “<” shaped marking on the outside surface of the outer rings of matched bearing sets

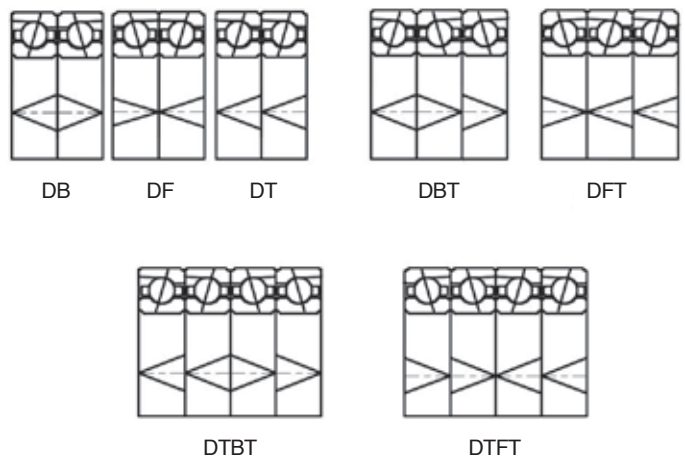

Fig.1.3. A “<” shaped marking on the outside surface of the outer rings of universal combination bearings

1.2.3 Flush Grinding and Universal Combination

In order to eliminate the face height differences, a finishing technique called "Flush Grinding" is used to make sure that the front and back faces of the inner ring and outer rings are aligned with each other (illustrated in Fig. 1.4). By doing so, specified clearance and preload for DF, DB, and DT sets are ensured, but it is only possible if the combined bearings have the same clearance/preload symbols.

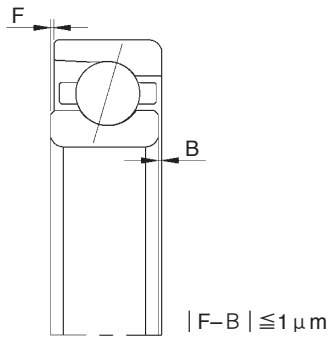

Fig.1.4 Flush grinding

If these combined bearings are used as part of multiple combined bearings, it is recommended that the variation of bore and outer diameter tolerance is within 1/3 of tolerance range. TPI bearings with special accuracy P4X can accommodate small variations of bore and outer diameter tolerance. P4X bearings have the same running accuracy as P4 while has a narrower tolerance range. It is suitable for random matching on universal combination bearings. It also brings convenience for customers to optimize their inventory with more precision P4X bearings.

Universal matching plays an important role in controlling the dimensional differences in the bore and outside diameters between duplex bearings.

When ordering bearings from TPI, please specify the desired number of duplex bearings to be used ("D2" for DB, DF or DT; "D3" for DBT, DFT or DTT). Simply indicate the basic combination and specify universal matching. For specific needs of bore and outside diameter of bearings, please contact TPI for customized tolerance.

1.2.4 Special P4X Accuracy

P4X bearings can control the bearing-to-bearing difference in the bore and outside diameters to no more than one third the tolerance (a minimum of 2 μm) as shown in Table 1.2.

Table 1.2 Tolerance of P4 and P4X Accuracy

Tolerance of bore diameter of inner ring unit: μm

Bore diameter (mm)		P4		P4X	
Over	Incl	High	Low	High	Low
30	50	0	-6	-2	-4
50	80	0	-7	-2	-5
80	120	0	-8	-3	-6
120	150	0	-10	-3	-7

Tolerance of outer diameter of outer ring unit: μm

Outer diameter (mm)		P4		P4X	
Over	Incl	High	Low	High	Low
50	80	0	-7	-2	-6
80	120	0	-8	-2	-6
120	150	0	-9	-3	-7
150	180	0	-10	-3	-7

1.2.5 Double-row cylindrical roller bearings

Cylindrical roller bearing is able to support larger radial load than point-contact ball bearing, since the rollers and raceways are in linear contact. Its structure is also suitable for high-speed operation.

TPI's double-row cylindrical roller bearings are available in two types: NN and NNU, and two series: 30 and 49. The rollers in the NN type are guided by the ribs of inner ring; whereas the rollers in the NNU type are guided by the ribs of the outer ring. Tapered bore type (allows adjustment of radial internal clearance of bearing) or a standard cylindrical bore are available for selection. In addition, TPI offers the standard type and high-speed type to satisfy our customer's demands. For standard type, a set of machined brass cages are used while high temperature special molded resin cages for high-speed applications. They can be used for both grease lubrication and air-oil lubrication.

1.2.6 Angular Contact Thrust Ball Bearings

A range of thrust bearings used in machine tools for the main spindles. They includes 5629 and 5620 series for high axial rigidity. These bearings are used in conjunction with double-row cylindrical roller bearings (matched bearings must have the same bore and outside diameter).

These duplex angular contact ball bearing series have similar design to the double-row thrust angular contact ball bearing series, but are different in terms of their width. Since their contact angles are lower at 40° and 30°, the series boast high speed capability. However, their axial rigidity is less than double-row thrust angular contact ball bearings with 60° contact angle.

1.3 Ball Screw Support Bearings

Ball Screw Support (BS) Bearings have the maximum possible number of small balls and thicker inner & outer rings, with the contact angle at 60°. This design allows greater axial rigidity. Since balls are used instead of rollers as rolling elements, starting torque is thus less than roller bearings.

Flushing grinding technique is used to ensure that the face height differences of BS type bearings are the same on both sides. This advantage allows the users to freely combine bearings with the same part numbers into DB, DBT, DTBT arrangements, and there is no need to adjust relevant preload anymore. It is also available for special request on bearing material, grease, sealing and so on. Please contact TPI for further information.

The BS type is mainly installed on ball screws of machine tool feed systems, and two to four rows arrangements are used in many cases. Both back-to-back and face-to-face duplex arrangement are used in this application. The face-to-face duplex arrangement may be used if misalignment is un-avoidable as shown in Fig.1.5.

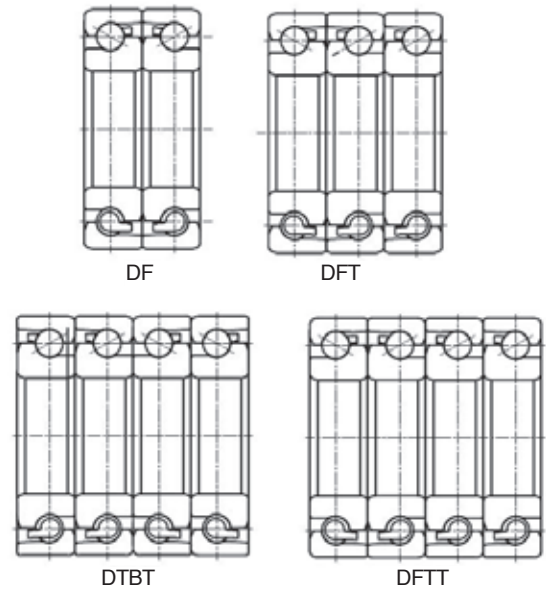

Fig.1.5 Two to four row arrangements are used on ball screws of machine tool feed systems

2 Bearing Number Codes

2.1 Bearing Designations

Rolling bearing part numbers indicate bearing type, dimensions, tolerances, internal construction, and other related specifications. Bearing numbers

are comprised of a "basic number" followed by "supplementary codes." The makeup and order of bearing numbers is shown in Table 2.1, 2.2.

Table 2.1 Number and code arrangement for angular contact ball bearings

	5S1-7 0 14 C T2 DB G / GNP4	
Ball Material	_____	Accuracy
Bearing Type	_____	Preload
Dimension Symbol	_____	Flush Grinding
Bore Number	_____	Bearing Arrangement
Contact Angle	_____	Cage Symbol

Ball material	5S1-	Si ₃ N ₄ (Ceramic ball)	
	Blank	SUJ2 (Steel ball)	
Bearing type	7	Single-row angular contact ball bearing	
	HS	High speed angular contact ball bearing	
	BT	High speed Thrust angular contact thrust ball bearing	
	BS	Ball screw support bearing	
Diameter symbol	9	BS Shown (I.D.)(O.D.)	
	0		
	2		
	3		
Bore number	6		
	.		
	.		
Contact angle	20		
	C		15°
	CE1		18°
	AD	25°	
	A	30°	
	B	40°	
Cage symbol	Blank	60°	
	T1	Phenolic machined cage	
	T2	Engineering plastic molded cage	
Bearing arrangement	T3	Engineering plastic molded cage	
	DB	Back to back arrangement	
	DF	Face to face arrangement	
	DT	Tandem arrangement	
	DBT	Tandem and back to back (triple-row)	
	DTBT	Tandem and back to back (quad-row)	
Flush grinding	G	Flush ground type	
	Blank	Without flush ground	
Preload	GL	Light preload	
	GN	Normal preload	
	GM	Medium preload	
	GH	Heavy preload	
	GXX	Special preload	
Accuracy	P5	JIS standard class 5	
	P4	JIS standard class 4	
	P4X	JIS standard class 4 ∙ Special bore and outside diameter tolerance	
	P4L	JIS standard class 4 ∙ Special outer diameter tolerance	
	P42	JIS standard class 4(dimensional) ∙ JIS standard class 2(running accuracy)	
	P4A	JIS standard class 4 ∙ Special bore and outside diameter tolerance	
	P2	JIS standard class 2	

Table 2.2 Number and code arrangement for double-row cylindrical roller bearings

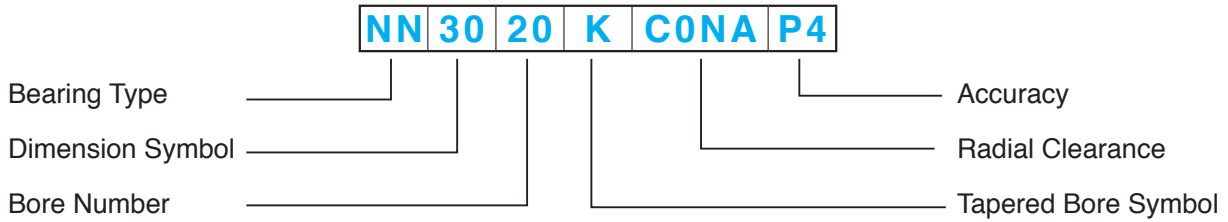

Bearing type	NN	Double row with ribbed inner ring
	NNU	Double row with ribbed outer ring
Dimension symbol	30	
	49	
Bore number	11	
	.	
	34	
Cage symbol	T2	Engineering plastic molded cage
	Blank	Machined brass
Tapered bore symbol	K	Tapered inner ring bore ,taper ratio1/12
	Blank	Cylindrical inner ring bore
Radial clearance	C0NA	Internal clearance smaller than Normal
	C1NA	Internal clearance smaller than Normal
	C2NA	Internal clearance smaller than Normal
	NA	Normal internal clearance
Accuracy	P5	JIS standard class 5
	P4	JIS standard class 4
	P2	JIS standard class 2

2.2 Bearing Marking

Each TPI high precision bearing is marked with various identifiers on one side face of the inner and outer ring as shown in Fig. 2.1. Outer diameter and width deviation from the nominal diameter are marked on the outer ring, bore diameter and offset of flush side face on the inner ring. “\” marks the position of the maximum eccentricity.

2.3 Comparison Table of TPI bearings with Other Brand Bearings

For user’s convenience, Table 2.3 lists TPI bearing number codes with those of other brand bearings side by side as quick reference to identify bearing characteristics including bearing series, dimensions, tolerance, and other internal structure etc.

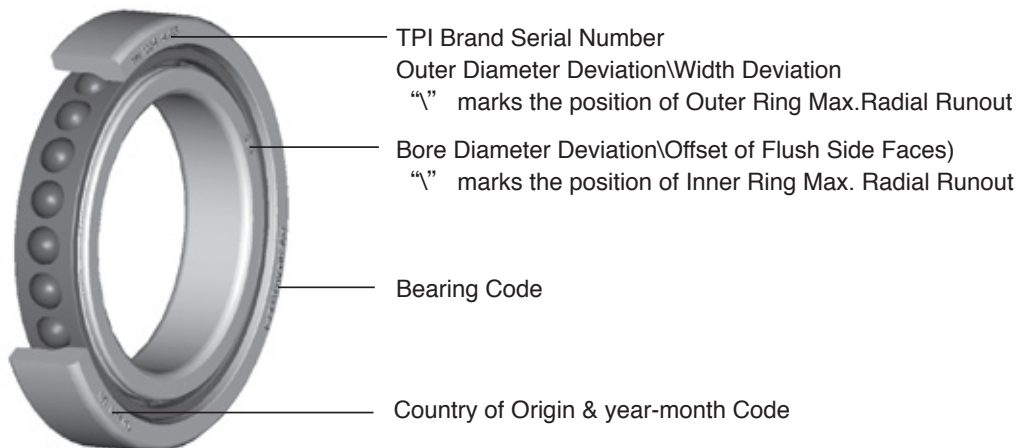

Fig.2.1 Bearing marking designation

Table 2.3 Comparison Table of TPI bearings with other brand bearings

		Code						Explanation	
Brand	TPI	NTN	NSK	FAG	SKF	GMN			
Basic numbers	Ball material	5S1-	5S-	H	HC	C,HC	HY	Si ₃ N ₄ Ceramic balls	
		Blank	Blank	Blank	Blank	Blank	Blank	SUJ2	
	Bearing type	7	7	7	B7	7	S	Standard type ACBB	
		HS	HSE	BNR,BER	HS,HC	B,E	KH	High Speed Type ACBB	
		BS	BST	TAC	BSB	BSD	—	Ball Screw Support Bearing (60° angle)	
	Diameter series	9	9	9	19	19	19	BS shown I.D.x O.D.	
		0	0	0	0	0	0		
		2	2	2	2	2	2		
		3	3	3	3	3	3		
	Bore diameter number	6	6	6	6	6	6		
		:	:	:	:	:	:		
		20	20	20	20	20	20		
	Contact angle	C	C	C	C	CD,CE	C		15°
		CE1	—	(BNR)	—	F	18°		18°
		AD	AD	A5,(BER)	E	AC	E		25°
	Cage symbol	T1	T1	TR	T	—	TA	Phenolic machined cage	
		T2	T2	TYN	—	TN,TN9	—	Engineering plastic molded cage	
		T3	—	—	—	—	TXM	Engineering plastic molded cage	
	Matching code	DB	DB	DB	DB	DB	DB	Back to back (double-row)	
		DF	DF	DF	DF	DF	DF	Face to face (double-row)	
		DT	DT	DT	DT	DT	DT	Tandem (double-row)	
		DBT	DBT	DBD	TBT	TBT	TBT	Tandem and back to back (triple-row)	
		DTBT	DTBT	DBB	QBC	QBC	QBC	Tandem and back to back (quad-row)	
	Flush grinding	G	G	SU	U	G	—	Flush ground type	
	Preload	GL	GL	EL	—	A	UL	Light preload	
		GN	GN	L	L	B	UM	Normal preload	
		GM	GM	M	M	C	US	Medium preload	
		GH	—	H	H	—	—	Heavy preload	
		Gxx	Gxx	CA	—	Gxxx	UV	Special preload	
	Accuracy	P4	P4	P4	—	P4	P4	JIS standard Class 4	
P4X		—	P4Y	—	—	—	JIS standard Class 4、Special bore and outside diameter tolerance		
P42		P42	P3	P4S	P4A	—	Dimensional precision JIS standard Class 4; running accuracy JIS standard Class 2		
P2		P2	P2	—	PA9A	P2	JIS standard Class 2		

3 Bearing Tolerance and Fits

3.1 Bearing Tolerance

Bearing “tolerances” or dimensional accuracy and running accuracy are regulated by ISO 492:2002 and JIS B 1514 standards (rolling bearing tolerances) shown in Table 3.1.

When mounting a bearing to a shaft or housing, the dimensional accuracy is crucial in satisfying the tolerance. A permissible run-out occurring when rotating a bearing by one revolution is defined by the running accuracy. Appendix III shows bearing accuracy for angular contact ball bearings, BS series bearings, and cylindrical roller bearings. Methods for measuring the accuracy of rolling bearings are described in JIS B 1515 and in Table 3.2.

Table 3.1 Bearing types and applicable tolerance and comparison of tolerance classifications of national standards

Table 3.1 Bearing type and tolerance classes						
Bearing type		Applicable Tolerance Class				
Deep Groove Ball Bearings		Normal	Class 6	Class 5	Class 4	Class 2
Angular Contact Ball Bearings		Normal	Class 6	Class 5	Class 4	Class 2
Cylindrical Roller Bearings		Normal	Class 6	Class 5	Class 4	Class 2
Needle Roller Bearings		Normal	Class 6	Class 5	Class 4	—
Tapered Roller Bearings	Metric Design	Class 0,6X	—	Class 5	Class 4	—
	Inch Design	ANSI/ABMA CLASS 4	ANSI/ABMA CLASS 2	ANSI/ABMA CLASS 3	ANSI/ABMA CLASS 0	ANSI/ABMA CLASS 00
Thrust Ball Bearing		Normal	Class 6	Class 5	Class 4	—
Double row angular contact thrust ball bearing		—	—	Class 5	Class 4	—

Equivalent standards (Reference)		Applicable Tolerance Class				
JIS ⁽¹⁾		Class 0	Class 6	Class 5	Class 4	Class 2
DIN ⁽²⁾		P0	P6	P5	P4	P2
ANSI/ABMA ⁽³⁾	Ball Bearing	ABEC1	ABEC3	ABEC5	ABEC7	ABEC9
	Roller Bearing	RBEC1	RBEC3	RBEC5	—	—
	Tapered Roller Bearing	CLASS 4	CLASS 2	CLASS 3	CLASS 0	CLASS 00

NOTE: (1) JIS: Japanese Industrial Standards (JIS B 1514)

(2) Deutsch Industries Norm (DIN 620)

(3) ANSI/ABMA: The American Bearing Manufacturers Association

Table 3.2 Measuring methods for running accuracies

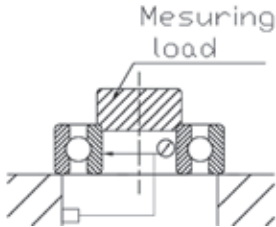
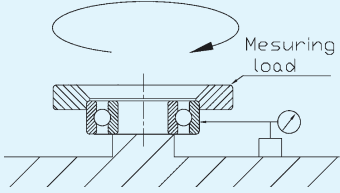
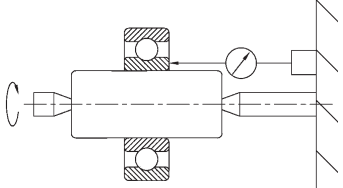
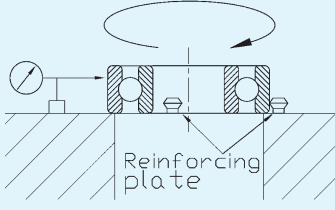
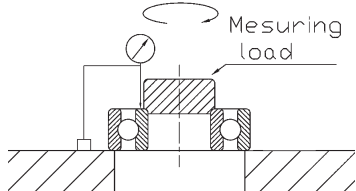
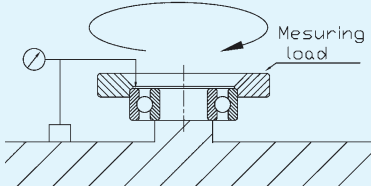
Running accuracy	Measurement principle
K_{ia} = Inner ring radial runout	
K_{ea} = Outer ring radial runout	
S_d = Inner ring side runout with bore	
S_D = Outer ring outside surface inclination	
S_{ia} = Inner ring axial runout	
S_{ea} = Outer ring axial runout	

A super-precision bearing that conforms to the user's main spindle specifications must be chosen in order to attain a higher level of running accuracy required of a main spindle of machine tool. A super-precision bearing of JIS accuracy class 5, 4, or 2 is usually selected according to its application. The main spindle's running accuracy needs to be strictly controlled because it is affected by the radial run-out, axial run-out and non-repetitive run-out of the main spindle bearing. The super precision machine tools requires finely controlled N.R.R.O. (Non-Repetitive Run-out), therefore the main spindle on a turning machine or machining center often utilizes N.R.R.O. accuracy controlled bearings.

TPI's cylindrical roller bearings comply with JIS Classes 4 and 2 specifications, as shown in Table 3.3. Poor accuracies of the tapered bore may lead to misalignment of the inner ring, causing poor performance of the bearing; in severe cases, premature seizure and flaking may occur. Using a taper gauge is recommended for achieving higher accuracy on the main spindle. Please refer to "8. Bearing Handling: 8.6 Clearance adjustment for cylindrical roller bearing" for more information on taper angle.

3.2 Accuracies of Shaft and Housing

The bearing's internal clearance may vary, depending on the fit of a bearing to a shaft and a housing. It is important to make sure that an adequate bearing fit is attained to achieve desired bearing performance. Table 3.4 and 3.5 show the accuracies of shaft and housing.

The axial tightening torque on a bearing should be carefully considered, because too much axial tightening may cause deformation of the bearing raceway surface. Please take time to carefully determine the dimensions of components associated with a tightening force, the magnitude of tightening force, and the number of tightening bolts.

When designing a bearing and housing, in order to maintain bearing and housing accuracies and also to avoid interference with the bearing related corner radius, it is important to provide a sufficient shoulder height for the bearing and housing. Table 3.6 shows the chamfer dimensions and the recommended shoulder height. Table 3.7 lists the corner radius on the shaft and housing. Relief dimensions for ground shaft and housing fitting surfaces are given in Table 3.8.

Table 3.3 Tolerance of taper-bored bearings

d (mm)		Δd_{mp}		Reference $\Delta d_{1mp} - \Delta d_{mp}$		V_{dp}
over	incl.	high	low	high	low	max
18	30	+13	0	+3	0	4
30	50	+16	0	+3	0	5
50	80	+19	0	+4	0	6
80	120	+22	0	+5	0	7
120	180	+25	0	+7	0	9
180	250	+29	0	+9	0	12

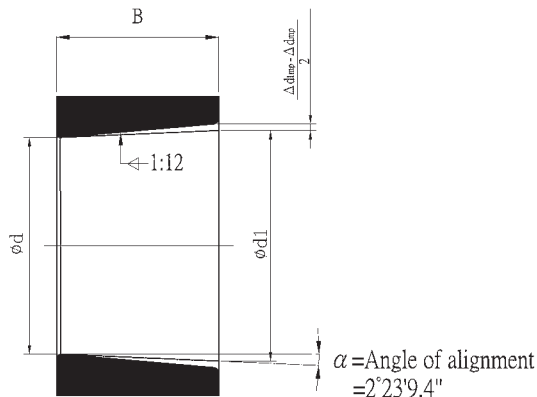

Δd_{mp} : Single plane mean bore diameter deviation in the theoretical small bore end of the bore

Δd_{1mp} : Single plane mean bore diameter deviation in the theoretical large bore end of the bore

Table 3.4 Form accuracy of spindle

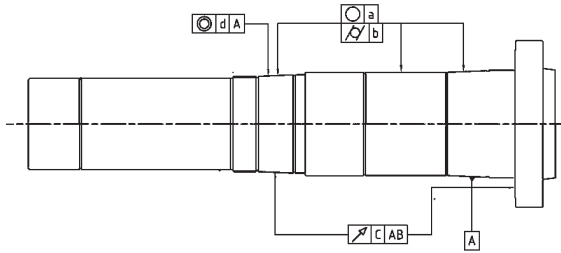

Shaft Diameter (mm)		Roundness(○)			Cylindricity(ϕ)			Runout(\nearrow)			Concentricity(◎)			Roughness		
		a			b			c			d			R _a		
		Bearing Accuracy			Bearing Accuracy			Bearing Accuracy			Bearing Accuracy			Bearing Accuracy		
over	incl	P5	P4	P2	P5	P4	P2	P5	P4	P2	P5	P4	P2	P5	P4	P2
-	10	1.3	0.8	0.5	1.3	0.8	0.5	2	2	1.3	4	4	2.5	0.2	0.2	0.1
10	18	1.5	1	0.6	1.5	1	0.6	2.5	2.5	1.5	5	5	3	0.2	0.2	0.1
18	30	2	1.3	0.8	2	1.3	0.8	3	3	2	6	6	4	0.2	0.2	0.1
30	50	2	1.3	0.8	2	1.3	0.8	3.5	3.5	2	7	7	4	0.2	0.2	0.1
50	80	2.5	1.5	1	2.5	1.5	1	4	4	2.5	8	8	5	0.2	0.2	0.1
80	120	3	2	1.3	3	2	1.3	5	5	3	10	10	6	0.4	0.4	0.2
120	180	4	2.5	1.8	4	2.5	1.8	6	6	4	12	12	8	0.4	0.4	0.2
180	250	5	3.5	2.3	5	3.5	2.3	7	7	5	14	14	10	0.4	0.4	0.2

Table 3.5 Form accuracy of housing

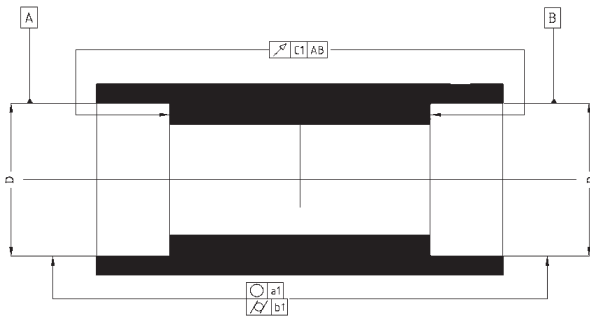

Housing bore diameter (mm)		Roundness(○)			Cylindricity(ϕ)			Runout(\nearrow)			Concentricity(◎)			Roughness		
		a			b			c			d			R _a		
		Bearing Accuracy			Bearing Accuracy			Bearing Accuracy			Bearing Accuracy			Bearing Accuracy		
over	incl	P5	P4	P2	P5	P4	P2	P5	P4	P2	P5	P4	P2	P5	P4	P2
-	10	1.3	0.8	0.5	1.3	0.8	0.5	2	2	1.3	4	4	2.5	0.4	0.4	0.2
10	18	1.5	1	0.6	1.5	1	0.6	2.5	2.5	1.5	5	5	3	0.4	0.4	0.2
18	30	2	1.3	0.8	2	1.3	0.8	3	3	2	6	6	4	0.4	0.4	0.2
30	50	2	1.3	0.8	2	1.3	0.8	3.5	3.5	2	7	7	4	0.4	0.4	0.2
50	80	2.5	1.5	1	2.5	1.5	1	4	4	2.5	8	8	5	0.8	0.8	0.4
80	120	3	2	1.3	3	2	1.3	5	5	3	10	10	6	0.8	0.8	0.4
120	180	4	2.5	1.8	4	2.5	1.8	6	6	4	12	12	8	0.8	0.8	0.4
180	250	5	3.5	2.3	5	3.5	2.3	7	7	5	14	14	10	1.6	1.6	0.8

Table 3.6 Allowable critical-value of bearing chamfer Radial bearings

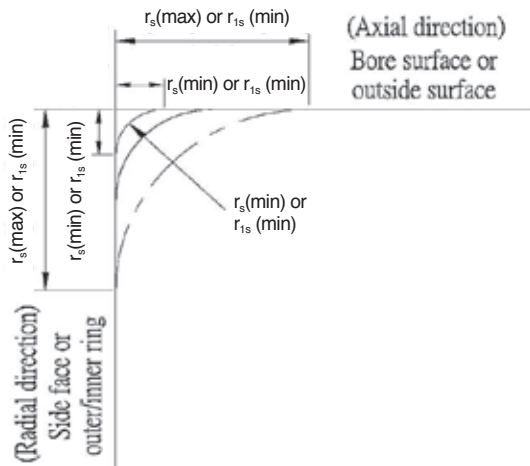

● These are the allowable minimum dimensions of the chamfer dimension "r_s" or "r_{1s}" and are described in the dimensional table.

Unit : mm

Permissible Chamfer Dimension: r _s (min) or r _{1s} (min)	Nominal Bore Diameter		Permissible Chamfer Dimension: r _s (max) or r _{1s} (max)	
	d		Radial Direction	Axial Direction
	over	incl		
0.05	—	—	0.1	0.2
0.08	—	—	0.16	0.3
0.1	—	—	0.2	0.4
0.15	—	—	0.3	0.6
0.2	—	—	0.5	0.8
0.3	—	40	0.6	1
0.3	40	—	0.8	1
0.6	—	40	1	2
	40	—	1.3	2
1	—	50	1.5	3
	50	—	1.9	3
1.1	—	120	2	3.5
	120	—	2.5	4
1.5	—	120	2.3	4
	120	—	3	5
2	—	80	3	4.5
	80	220	3.5	5
	220	—	3.8	6

Table 3.7 Fillet radius and abutment height

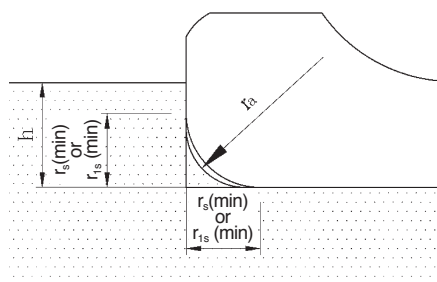

Unit : mm

Nominal Chamfer Dimensions	Fillet Radius	Minimum Shoulder Heights
r _s (min) or r _{1s} (min)	r _a (max)	h (min)
0.05	0.05	0.3
0.08	0.08	0.3
0.1	0.1	0.4
0.15	0.15	0.6
0.2	0.2	0.8
0.3	0.3	1.25
0.6	0.6	2.25
1	1	2.75
1.1	1	3.5
1.5	1.5	4.25
2	2	5
2.1	2	6
2.5	2	6
3	2.5	7
4	3	9
5	4	11
6	5	14
7.5	6	18
9.5	8	22
12	10	27
15	12	32
19	15	42

If bearing supports large axial load, the height of the shoulder must exceed the value given here.

Note: r_a (max) maximum allowable filler radius.

Table 3.8 Relief dimensions for grinding

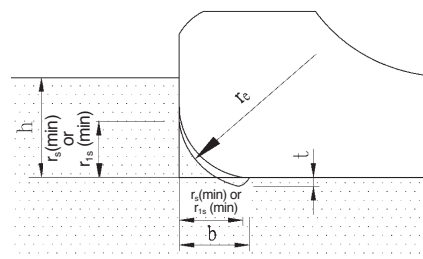

Unit : mm

Chamfer Dimensions of Inner and Outer	Relief Dimensions		
	r _s (min) or r _{1s} (min)	b	r _e
1	2	1.3	0.2
1.1	2.4	1.5	0.3
1.5	3.2	2	0.4
2	4	2.5	0.5
2.1	4	2.5	0.5
2.5	4	2.5	0.5
3	4.7	3	0.5
4	5.9	4	0.5
5	7.4	5	0.6
6	8.6	6	0.6
7.5	10	7	0.6

3.3 Shaft and Housing Fits

The performance of bearings such as speed capability and running accuracy is influenced by the seats and the precision of the selected fits of shaft and housing. Recommended fits for general operating conditions at inner ring rotation of precision bearings used for machine tools are shown in Tables 3.9, 3.10 and 3.11. If the dmN value (d_m : pitch circle diameter across rolling elements [mm] multiplied by speed [min^{-1}]) is higher than the value of one million, one should consider the expansion of inner ring caused by

centrifugal force. It also influences preload in bearings. In this case, more detailed analysis is needed from some simulation tools such as TH-BBAN software for determining bearing fit and possibly increasing interference fit to compensate the centrifugal effect.

For ball screw support bearings (BS series type) recommended fit of shaft and housing are h5 and H6 respectively. The tolerances of shoulder squareness is within 4 μm for diameter less than 80 mm.

Table 3.9 Shaft fit for high precision bearings

Bearing type	Shaft diameter (mm)		Bearing accuracy class			
			Class 5		Class 4 /Class 2	
	over	incl.	Desired fit	Shaft tolerance	Desired fit	Shaft tolerance
Angular contact ball bearing	10	18	0~2T	h4	0~2T	h3
	18	50	0~2.5T	h4	0~2.5T	h3
	50	80	0~3T	h4	0~3T	h3
	80	150	0~4T	js4	0~4T	js3
	150	200	0~5T	js4	0~5T	js3
Cylindrical roller bearing (cylindrical bore)	25	40	—	js4	—	js4
	40	140	—	k4	—	k3
	140	200	—	k4	—	k3
high speed thrust angular contact ball bearing	For all shaft diameters		0~6L	h4	0~6L	h4
Ball screw support bearings	For all shaft diameters		0~10L	h5	0~10L	h5

Table 3.10 Housing fit (fixed side) for high precision bearings

Bearing type	Housing bore diameter (mm)		Bearing accuracy class			
			Class 5		Class 4 /Class 2	
	over	incl.	Desired fit	Housing bore tolerance	Desired fit	Housing bore tolerance
Angular contact ball bearing	18	50	0~3L	JS4	0~3L	JS3
	50	120	0~4L	JS4	0~4L	JS3
	120	180	0~5L	JS4	0~5L	JS3
	180	250	0~6L	JS4	0~6L	JS3
Cylindrical roller bearing (cylindrical bore)	Overall housing bore		± 0	K5	± 0	K5
high speed thrust angular contact ball bearing	Overall housing bore		30L~40L	K5	30L~40L	K5
Ball screw support bearings	Overall housing bore		10L~20L	H6	10L~20L	H6

Table 3.11 Housing fit (free side) for high precision bearings

Bearing type	Housing bore diameter (mm)		Bearing accuracy class			
			Class 5		Class 4 /Class 2	
	over	incl.	Desired fit	Housing bore tolerance	Desired fit	Housing bore tolerance
Angular contact ball bearing	18	50	6L~10L	H4	6L~10L	H3
	50	120	8L~13L	H4	8L~13L	H3
	120	180	12L~18L	H4	12L~18L	H3
	180	250	15L~22L	H4	15L~22L	H3
Cylindrical roller bearing (cylindrical bore)	Overall housing bore		±0	K5	±0	K4
Ball screw support bearings	Overall housing bore		10L~20L	H6	10L~20L	H6

4 Bearing Load Rating and Life

Even under normal conditions, the surfaces of the raceway and rolling elements of a bearing are subjected to repeated compressive stresses, which will eventually cause flaking of these surfaces to occur. Flaking is a sign of material fatigue, which may eventually lead to bearing failure. A bearing's effective life is usually defined by the total number of revolutions the bearing can undergo before flaking on either the raceway surface or rolling element surfaces occur.

Others causes of bearing failure may include seizing, abrasions, cracking, chipping, gnawing, rust, etc. These "causes" are often related to improper installation, insufficient or improper lubrication, faulty sealing or inaccurate bearing matching or selection. In another word, man-caused bearing failure can be avoided by taking precautions, and they should be separately considered from the flaking aspect that is related to material fatigue.

In most cases, the load exerted on the main spindle of a machine tool is relatively small compared to the dynamic load on the bearing. Therefore, the fatigue life of a bearing seldom poses a problem. Rather, bearing size is almost determined by other factors such as system rigidity or fixed dimensions of the spindle as well as the speed and feed parameters of the application.

4.1 Basic Rating Life and Basic Dynamic Load Rating

The general information about bearing life calculation and basic load ratings is also valid for high precision bearings. It should be noted that all life calculations are based on ISO 281:2007.

The basic rating life for a radial ball bearing is given by the life equation:

$$L_{10} = \left(\frac{C_r}{P} \right)^p$$

where

L_{10} : basic rating life at 90% reliability, millions of revolutions

p : exponent of the life equation

: 3 for ball bearings

: 10/3 for roller bearings

C_r : Basic dynamic load rating (N or kgf)

P : The equivalent dynamic load (N or kgf)

The basic dynamic load rating C_r is also defined in ISO 281:2007. It expresses the bearing load that will provide a basic life on one million revolutions. It is assumed that the load is constant in magnitude and direction and is radial for radial bearings or axial for thrust bearings.

To calculate bearing life with basic dynamic load ratings, it is necessary to convert the actual dynamic loads into an equivalent dynamic bearings load. The equivalent dynamic bearing load P is defined as a hypothetical load, constant in magnitude and direction, acting radially for radial bearing or axially for thrust bearings. It is used to represent the effect that the actual load would have on bearing life.

The basic dynamic load rating and equivalent dynamic bearings load are listed in precision being tables for TPI standard bearing materials, using standard manufacturing techniques. Please consult TPI for basic load ratings of bearings constructed of special materials or using special manufacturing techniques.

When calculating the basic dynamic radial load rating for two similar single-row angular contact ball bearings mounted side by side on the same shaft, such that they operate as a unit (DB or DF arrangement), the pair is considered as one

double-row angular contact ball bearing. For two or more similar such bearings mounted side by side in a tandem arrangement, the basic dynamic radial load rating is the number of bearings to the power of 0.7 times the rating of one single-row bearing.

4.2 Correction factor of Bearing Life

Basic rating life (90% reliability), can be calculated by formula that we just mention at last section, however, when comes to more strict environment, we need higher than 90% reliability to meet the goal. Using special material and process technology can also prolong bearing life. Basic on the theory of Elastohydrodynamic Lubrication (EHL), service condition (lubricant \ temp. and velocity etc.) also the key factor to affect the bearing life.

$$L_{na} = a_1 a_2 a_3 \left(\frac{C}{P} \right)^p$$

When started to consider how these key factor could affect bearing life, we can add a correction factor base on ISO 281.

L_{na} : Bearing Life included reliability \ material and service condition these factor.

a_1 : Reliability correction factor

a_2 : Material and process technology correction factor

a_3 : Service condition correction factor

All of the factor please refer to TPI if you need.

4.3 Static Load Rating and Allowable Axial Load

In practice, permanent deformations of small magnitude occur even under light loads. If the deformations become much larger, the cavities formed in the raceways cause the bearing to vibrate and become noisier. Moreover, indentations together with conditions of marginal lubrication can lead to surface-initiated fatigue.

Experience has shown that permanent deformations have little effect on the operation of the bearing if the magnitude at any given contact point is limited to a maximum of 0.0001 times the diameter of the rolling element.

The basic static load rating of a rolling bearing is defined as that load applied to a non-rotating bearing that will result in permanent deformation of 0.0001 times the diameter of the rolling element at

the weaker of the inner or outer raceway contacts occurring at the position of the maximum loaded rolling element. For ball bearings, the maximum applied load value for contact stress occurring at the rolling element and raceway contact points are 4200MPa or 428kgf/mm².

A sufficient safety factor to protect the bearing from permanent deformation can be obtained when

$$S_o = \frac{C_o}{P_{o\ max}}$$

where,

$P_{o\ max}$: equivalent static bearing load (N or kgf)

C_o : basic static load rating (N or kgf)

S_o : static safety factor

The basic static load rating C_o is defined in ISO 76:2006. It corresponds to a calculated contact stress at the center of the most heavily loaded rolling element/raceway contact that produces a permanent deformation of the rolling element diameter. The loads are purely radial for radial bearings and axial for thrust bearings. The basic static load rating C_o is listed in the bearing tables.

To compare actual loads with the basic static load rating, the actual loads must be converted into an equivalent load. This is defined as that hypothetical load which, if applied would cause the same maximum rolling element load in the bearing as the loads to which the bearing is subjected.

4.4 Bearing Life for High Speed Application

For high-speed applications, the effects of ball centrifugal forces and gyroscopic moments need to be included. The force and moment equilibrium equations for the bearing inner ring are solved for the bearing axial, radial, and angular deflections. If the bearing has a complement of Z balls, then a system of 4Z+5 equations is solved numerically using the Newton-Raphson method.

For the analysis including the determination of ball friction forces and speeds, in addition to the 5 force and moment load equilibrium equations for the inner ring, the torques acting on the cage in the plane of bearing rotation are balanced, and cage speed is determined. In this case a system of 9Z+6 equations are solved numerically. TPI' s HS high-speed type angular contact ball bearings are optimally designed with their internal configuration to accommodate both low frictional heat or ball skidding effect and high rigidity by using TH-BBAN.

4.5 Life for Hybrid Bearings

When calculating the rating life for hybrid bearings, the same life values can be used as for all-steel bearings. The ceramic balls in hybrid bearings are much harder and stiffer than the all-steel bearings. Although this increased level of hardness and stiffness creates a higher degree of contact stress between the ceramic ball and the steel raceway, extensive experience and testing shows that in typical machine tool applications, the service life of hybrid bearing is significantly longer than that of all-steel bearing. The reasons for this are: 1) low density minimizes centrifugal and inertial forces; 2) low surface adhesive wear is reduced by the lower affinity to steel; and 3) better surface finish enables the bearing to maximize the effects of the lubricant.

5 Bearing Preload and Rigidity

5.1 Rigidity of Spindle

System rigidity in machine tool applications is extremely important because the magnitude of deflection under load determines machining accuracy. Bearing rigidity is only one factor that influences system rigidity; others include shaft diameter, tool overhang, housing rigidity number, position and type of bearings. For axial rigidity of spindles, bearing rigidity plays an important role of it. Giving preload to a bearing result in the rolling element and raceway surfaces being under constant elastic compressive forces at their contact points. This has the effect of making the bearing extremely rigid so that even when load is applied to the bearing, radial or axial shaft displacement does not occur.

If high radial rigidity of bearing is needed, cylindrical roller bearings are normally used. In contrast to angular contact ball bearing, they provide more surface contact and gross sliding and are not suitable for very high-speed applications. For axial loading applications, angular contact ball bearings are normally used. Their larger contact angle type provides higher axial rigidity. The rigidity of this type also depends on number and size of balls. Recently, the ceramic material silicon nitride Si3N4 is used for precision ball bearings. The radial rigidity of this hybrid bearing is approximately 15% higher because of the higher Young's modulus. As mentioned in 4.5, TPI's HS type angular contact ball bearings are optimally designed with their internal configuration to accommodate both low-ball skidding effect and high rigidity by using TH-BBAN.

5.2 Bearing Preload

The preload method is divided into fixed position preload and constant pressure preload as shown in Fig. 5.1. The fixed position preload is effective for positioning the two bearings and also for increasing the rigidity. Due to the use of a spring for the constant pressure preload, the preloading amount can be kept constant, even when the distance between the two bearings fluctuates under the influence of operating heat and load.

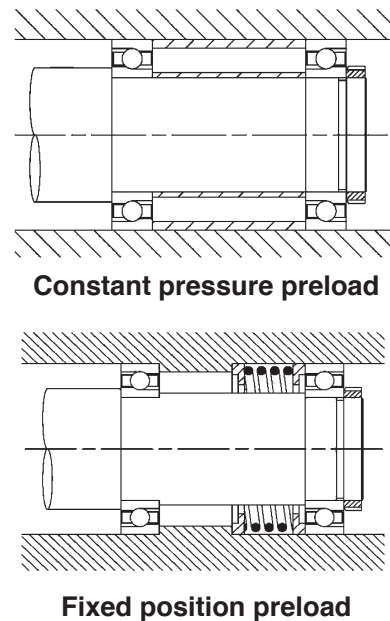

Fig. 5.1 Preloading methods for bearings

The increased rigidity effect preloading has on bearings is shown in Fig. 5.2. When the offset inner rings of the two paired angular contact ball bearings are pressed together, each inner ring is displaced axially by the amount δ_{a0} and is thus given a preload, F_{a0} , in the direction. Under this condition, when external axial load F_a is applied, bearing A will have an increased displacement by the amount δ_{a0} and bearing B's displacement will decrease. At this time the loads applied to bearing A and B are F_{aA} and F_{aB} , respectively. Under the condition of no preload, bearing A will be displaced by the amount δ_{a0A} when axial load F_a is applied. Since the amount of displacement, δ_{a1} , is less than δ_{a0A} , it indicates a higher rigidity for δ_a . When external axial load F_a keeps increasing until δ_{aA} equals to $2\delta_{a0A}$, that is $\delta_{aB}=0$. Now, bearing B becomes released from preload while bearing A is loaded with 2.83 times of given preload F_{a0} . This amount of load is called the limiting axial load and it may depend on bearing arrangement and contact angle.

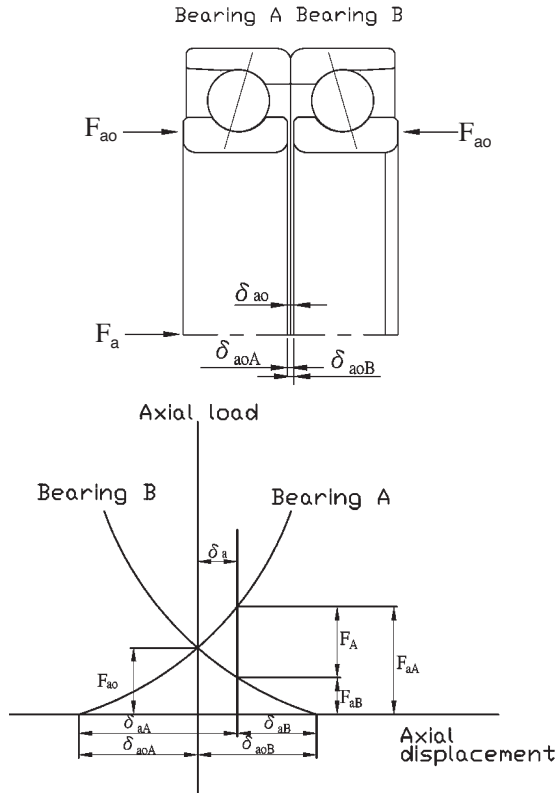

Fig. 5.2 Fixed position preload versus axial displacement

The resulting preload can be determined by a factor for its bearing arrangement as shown in Table 5.1. The value of resulting preload P_r is

$$P_r = P_1 \cdot P_{ro} \text{ (N)}$$

where P_{ro} can be obtained in Table 5.5

Table 5.1 Preload Factor P_1 for different bearing arrangements

Arrangement	Factor P_1
	1.00
	1.35
	1.60
	2.00

5.3 Rigidity of Angular Contact Ball Bearing

Elastic deformation in rolling bearings results in the rings being displaced relative to each other. For angular contact ball bearings, the following formula is used to calculate this relative displacement in a radial and axial direction:

$$\delta_r = 5.848 \times 10^{-3} \cdot F_r^{2/3} \cdot (iZ)^{-2/3} \cdot D_w^{-1/3} \cdot \cos \alpha^{-5/3}$$

$$\delta_a = 2 \times 10^{-3} \cdot F_a^{2/3} \cdot (iZ)^{-2/3} \cdot D_w^{-1/3} \cdot \sin \alpha^{-5/3}$$

where δ_r : radial displacement under pure radial load, mm

δ_a : axial displacement under pure axial load (mm)

F_r : pure radial load (kgf)

F_a : pure axial load (kgf)

i : No. of row

Z : No. of balls per row

D_w : ball pitch diameter (mm)

α : contact angle (degrees)

In Table 5.5, the (axial) rigidity is defined as the external axial load of a bearing set in DB or DF arrangement, which causes a deflection of 1 micron of the bearing rings to each other. Before reaching to limiting axial load, bearing rigidity can be consistently measured and the result is close to the calculated value under light and normal preload. However, for bearings under medium and heavy preload, the calculated value becomes doubtful because change of initial and final contact angles. The above formula for radial and axial displacements is not valid under heavy load and need more rigorous analytical computer program such as TH-BBAN program to solve it.

Radial rigidity varies with contact angle and preload. In contrast to the axial rigidity, radial rigidity decreases as contact angle increases and changes markedly as a function of the ratio between axial and external loads applied to the bearing. In practical manner, the radial and axial rigidity are determined as follows. Rigidity factors with various arrangements, contact angle, and preload in the formula can be obtained in Table 5.2 and 5.3.

$$R_r = q_1 \cdot q_2 \cdot R_a \text{ (N/}\mu\text{m)}$$

$$R_a = q_1 \cdot R_{ao}$$

where, q_1 : rigidity factor for bearing arrangement, please refer to Table 5.2

q_2 : rigidity factor for contact angle and preload, please refer to Table 5.3

R_{ao} : rigidity factor, please refer to Table 5.6

Table 5.2 Rigidity factor for bearings with various arrangements q_1

Arrangement	Radial factor q_1	Axial factor q_1
	1.00	1.00
	1.54	1.48
	2.00	2.00

Table 5.3 Rigidity factor for bearings with various arrangement and preload q_2

Preload \ Contact angle	L	N	M	H
15°	6.5	6.0	5.0	4.5
18°	4.5			—
25°	2.0			
30°	1.4			

5.4 Limiting Axial Load

Limiting axial load is the external axial load of a preloaded bearing pair or set that causes loss of contact between the balls and race in preload bearings. This effect may lead to balls skidding against the raceways and surface damage.

In some machine tools applications, where the working axial load is predominantly in one direction, limiting axial load can be increased by using a bearing set with a mixed contact angle. The axially more rigid bearing withstands the workload and the less rigid one is the reaction element. Table 5.4 is an example to address the above concept. Compared to the bearing set with

same contact angle, the bearing set with a mixed contact angle of 15 and 25 degrees withstands higher 5.9 times of axial preload load (compared to 2.83 times of preload). Furthermore, it could be considered that increasing their contact angle by 3~5 degree, bearings withstand their axial load may have 16 ~32% more limiting axial load and axial rigidity as well.

Table 5.4 Limiting axial load of bearings with an equal/a mixed contact angle and various arrangements

Unit : P_{ro} (N)

Arrangement	Limiting axial load			
	$\alpha_1 = \alpha_2$		$\alpha_1 = 25^\circ$ $\alpha_2 = 15^\circ$	
α contact angle 1: bearing withstands axial load; 2: bearing paired to bearing 1	P_{d1}	P_{d2}	P_{d1}	P_{d2}
DB	2.83	2.83	5.90	1.75
DBT	4.16	2.08	9.85	1.45
DTTB	5.40	1.80	13.66	1.33
DTBT	2.83	2.83	5.90	1.75

Table 5-5(1) Preload and Rigidity (DB and DF Arrangement) of 70C standard series

Bearing Number	Bore d (mm)	Bearing Preload, Rigidity, and Measured Face Side Offset							
		L		N		M		H	
		Preload P_{ro} (N)	Rigidity R_{ao} (N/ μ m)	Preload P_{ro} (N)	Rigidity R_{ao} (N/ μ m)	Preload P_{ro} (N)	Rigidity R_{ao} (N/ μ m)	Preload P_{ro} (N)	Rigidity R_{ao} (N/ μ m)
7000C	10	15	14	30	19	85	30	165	43
7001C	12	15	14	35	19	85	31	170	43
7002C	15	20	17	40	23	100	37	195	51
7003C	17	20	19	40	25	105	39	205	55
7004C	20	35	24	65	32	180	51	345	71
7005C	25	35	26	70	35	185	54	360	76
7006C	30	45	31	90	41	240	64	470	90
7007C	35	55	36	115	48	305	75	595	104
7008C	40	60	40	125	53	330	83	640	115
7009C	45	75	44	145	58	390	90	755	125
7010C	50	80	48	155	63	415	99	805	137
7011C	55	100	53	205	71	545	110	1060	152
7012C	60	105	56	210	74	560	115	1085	159
7013C	65	110	61	225	80	595	124	1150	172
7014C	70	140	67	280	88	750	136	1455	188
7015C	75	145	69	290	92	770	141	1490	195
7016C	80	175	75	350	99	940	153	1820	211
7017C	85	180	78	360	103	965	158	1865	218
7018C	90	215	83	430	109	1145	169	2220	233
7019C	95	220	86	440	114	1175	175	2280	241
7020C	100	225	90	450	118	1205	182	2335	250

(70 series C angle: 15° nominal contact angle, steel ball)

Table 5-5(2) Preload and Rigidity (DB and DF Arrangement) of 70AD standard series

Bearing Number	Bearing Preload, Rigidity, and Measured Face Side Offset								
	Bore <i>d</i> (mm)	L		N		M		H	
		Preload P_{r0} (N)	Rigidity R_{a0} (N/ μ m)	Preload P_{r0} (N)	Rigidity R_{a0} (N/ μ m)	Preload P_{r0} (N)	Rigidity R_{a0} (N/ μ m)	Preload P_{r0} (N)	Rigidity R_{a0} (N/ μ m)
7000AD	10	25	34	45	43	140	67	270	89
7001AD	12	25	34	45	44	140	67	275	89
7002AD	15	25	40	55	52	160	80	315	106
7003AD	17	30	44	55	56	170	86	335	114
7004AD	20	50	57	95	73	285	112	565	149
7005AD	25	50	61	100	78	300	120	590	159
7006AD	30	65	72	130	93	390	142	765	188
7007AD	35	80	85	165	109	490	166	965	220
7008AD	40	90	94	175	121	525	184	1035	243
7009AD	45	105	103	210	132	625	201	1225	265
7010AD	50	110	113	220	145	665	221	1305	290
7011AD	55	145	126	290	162	875	246	1715	324
7012AD	60	150	131	300	169	895	257	1760	338
7013AD	65	160	143	315	184	945	279	1860	366
7014AD	70	200	157	400	202	1200	306	2355	402
7015AD	75	205	163	410	210	1225	318	2405	418
7016AD	80	250	176	500	227	1500	343	2945	451
7017AD	85	255	184	510	236	1535	357	3015	469
7018AD	90	305	195	610	251	1830	380	3595	499
7019AD	95	315	203	625	261	1875	396	3685	519
7020AD	100	320	211	640	272	1920	411	3775	538

(70 series AD angle:25° nominal contact angle, steel ball)

Table 5-5 (3) Preload and Rigidity (DB and DF Arrangement) of 70 A standard series

Bearing number	Bore <i>d</i>	Bearing Preload, Rigidity, and Measured Face Side Offset					
		L		N		M	
		Preload P_{r0} (N)	Rigidity R_{a0} (N/ μ m)	Preload P_{r0} (N)	Rigidity R_{a0} (N/ μ m)	Preload P_{r0} (N)	Rigidity R_{a0} (N/ μ m)
7000A	10	20	39	65	59	130	77
7001A	12	20	39	66	60	131	78
7002A	15	20	44	75	71	151	93
7003A	17	20	47	79	76	158	99
7004A	20	40	65	134	100	268	130
7005A	25	40	65	140	108	281	140
7006A	30	50	80	181	128	361	166
7007A	35	65	94	228	150	455	194
7008A	40	65	102	237	164	473	213
7009A	45	80	114	293	181	585	231
7010A	50	85	125	308	198	616	256

(70 series A angle:30° nominal contact angle, steel ball)

Table 5-5 (4) Preload and Rigidity (DB and DF Arrangement) of 72C standard series

Bearing Number	Bearing Preload、Rigidity、and Measured Face Side Offset								
	Bore d (mm)	L		N		M		H	
		Preload P_{r0} (N)	Rigidity R_{a0} (N/ μ m)	Preload P_{r0} (N)	Rigidity R_{a0} (N/ μ m)	Preload P_{r0} (N)	Rigidity R_{a0} (N/ μ m)	Preload P_{r0} (N)	Rigidity R_{a0} (N/ μ m)
7200C	10	15	14	30	19	85	31	170	43
7201C	12	20	17	40	22	115	35	220	49
7202C	15	25	19	55	25	145	40	280	56
7203C	17	35	21	65	28	180	44	345	62
7204C	20	45	25	85	34	235	53	450	75
7205C	25	50	30	100	40	265	62	515	87
7206C	30	70	35	140	47	370	74	715	103
7207C	35	90	40	180	54	485	85	940	118
7208C	40	110	46	220	62	580	96	1125	134
7209C	45	120	49	245	66	655	102	1265	142
7210C	50	130	52	255	70	685	109	1325	151
7211C	55	160	58	320	78	845	121	1640	167
7212C	60	190	64	385	86	1025	132	1985	184
7213C	65	210	67	420	90	1115	138	2165	192
7214C	70	230	70	455	93	1215	144	2355	200
7215C	75	240	74	475	99	1270	153	2460	212
7216C	80	280	80	555	107	1485	165	2875	229
7217C	85	310	88	625	118	1665	181	3230	251
7218C	90	370	92	735	124	1960	190	3800	263
7219C	95	415	98	835	132	2220	203	4305	280
7220C	100	445	98	895	132	2385	203	4620	280

(72 series C angle:15° nominal contact angle, steel ball)

Table 5-5 (5) Preload and Rigidity (DB and DF Arrangement) of HSCE1 standard series

Bearing Number	Bearing Preload、Rigidity、and Measured Face Side Offset								
	Bore d (mm)	L		N		M		H	
		Preload P_{r0} (N)	Rigidity R_{a0} (N/ μ m)	Preload P_{r0} (N)	Rigidity R_{a0} (N/ μ m)	Preload P_{r0} (N)	Rigidity R_{a0} (N/ μ m)	Preload P_{r0} (N)	Rigidity R_{a0} (N/ μ m)
HS000CE1	10	5	12	10	15	30	22	60	29
HS001CE1	12	5	12	10	15	30	22	55	29
HS002CE1	15	10	15	15	19	40	28	80	36
HS003CE1	17	10	16	15	20	40	29	80	38
HS004CE1	20	15	21	25	27	70	39	130	51
HS005CE1	25	15	22	25	28	70	41	135	53
HS006CE1	30	30	30	55	38	150	55	290	72
HS007CE1	35	35	33	70	43	185	61	355	80
HS008CE1	40	35	37	75	47	195	67	380	88
HS009CE1	45	40	40	75	52	205	73	400	95
HS010CE1	50	45	44	95	57	250	81	485	105
HS011CE1	55	50	49	100	62	270	90	520	117
HS012CE1	60	50	51	105	64	275	93	530	121
HS013CE1	65	60	56	120	70	325	102	630	132
HS014CE1	70	70	60	145	76	380	110	740	143
HS015CE1	75	80	68	155	86	420	125	810	163
HS016CE1	80	105	74	205	96	545	140	1060	182
HS017CE1	85	105	76	210	99	555	144	1080	188
HS018CE1	90	110	81	215	105	575	153	1120	199
HS019CE1	95	135	87	265	112	710	163	1375	213
HS020CE1	100	135	89	270	116	725	168	1400	219

(HS series CE1 angle:18° nominal contact angle, steel ball)

Table 5-5 (6) Preload and Rigidity (DB and DF Arrangement) of 5S1-70C standard series

Bearing Number	Bearing Preload、Rigidity、and Measured Face Side Offset								
	Bore d (mm)	L		N		M		H	
		Preload P_{ro} (N)	Rigidity R_{ao} (N/ μ m)	Preload P_{ro} (N)	Rigidity R_{ao} (N/ μ m)	Preload P_{ro} (N)	Rigidity R_{ao} (N/ μ m)	Preload P_{ro} (N)	Rigidity R_{ao} (N/ μ m)
5S1-7000C	10	20	17	40	23	100	36	195	51
5S1-7001C	12	20	17	40	23	105	37	200	52
5S1-7002C	15	25	21	45	28	120	44	230	61
5S1-7003C	17	25	22	50	30	125	47	245	66
5S1-7004C	20	40	29	80	39	210	61	410	85
5S1-7005C	25	45	31	85	41	220	65	430	90
5S1-7006C	30	55	37	110	49	285	76	555	107
5S1-7007C	35	70	43	135	57	360	89	705	124
5S1-7008C	40	75	48	145	63	390	98	755	137
5S1-7009C	45	90	52	175	69	460	107	895	149
5S1-7010C	50	95	57	185	76	490	117	955	162
5S1-7011C	55	125	63	245	84	645	131	1255	181
5S1-7012C	60	125	66	250	88	665	136	1290	188
5S1-7013C	65	135	72	265	96	705	147	1370	204
5S1-7014C	70	170	79	335	105	890	162	1730	224
5S1-7015C	75	175	82	345	109	915	168	1775	232
5S1-7016C	80	215	89	420	118	1120	181	2170	250
5S1-7017C	85	220	92	430	123	1145	188	2225	260
5S1-7018C	90	260	98	515	131	1365	200	2645	276
5S1-7019C	95	270	102	530	136	1405	208	2715	287
5S1-7020C	100	275	106	540	140	1435	216	2780	297

(5S1-70 series C angle:15° nominal contact angle, ceramic ball)

Table 5-5 (7) Preload and Rigidity (DB and DF Arrangement) of 5S1-HSCE1 standard series

Bearing Number	Bearing Preload、Rigidity、and Measured Face Side Offset								
	Bore d (mm)	L		N		M		H	
		Preload P_{ro} (N)	Rigidity R_{ao} (N/ μ m)	Preload P_{ro} (N)	Rigidity R_{ao} (N/ μ m)	Preload P_{ro} (N)	Rigidity R_{ao} (N/ μ m)	Preload P_{ro} (N)	Rigidity R_{ao} (N/ μ m)
5S1-HS000CE1	10	5	14	15	18	35	26	70	34
5S1-HS001CE1	12	5	14	15	18	35	26	70	34
5S1-HS002CE1	15	10	18	20	23	50	33	95	43
5S1-HS003CE1	17	10	18	20	24	50	34	95	45
5S1-HS004CE1	20	15	25	30	32	80	47	155	61
5S1-HS005CE1	25	15	26	30	34	80	48	160	63
5S1-HS006CE1	30	35	36	70	46	175	65	345	86
5S1-HS007CE1	35	40	40	85	51	215	73	425	96
5S1-HS008CE1	40	45	44	90	56	230	80	455	105
5S1-HS009CE1	45	45	48	95	62	245	87	490	115
5S1-HS010CE1	50	55	52	115	67	300	96	580	125
5S1-HS011CE1	55	60	58	115	73	320	107	630	140
5S1-HS012CE1	60	60	60	120	75	325	111	630	143
5S1-HS013CE1	65	75	67	145	84	385	121	745	156
5S1-HS014CE1	70	90	73	170	91	455	131	880	170
5S1-HS015CE1	75	100	82	190	102	495	148	970	195
5S1-HS016CE1	80	120	88	245	114	650	166	1260	217
5S1-HS017CE1	85	125	91	250	118	660	171	1280	223
5S1-HS018CE1	90	125	96	260	125	685	181	1330	237
5S1-HS019CE1	95	160	103	315	133	840	193	1635	253
5S1-HS020CE1	100	160	106	325	137	860	200	1665	260

(5S1-HS series CE1 angle:18° nominal contact angle, ceramic ball)

Table 5-6(1) Preload and Rigidity of 70A standard series

Bearing Number	Bore d (mm)	Bearing Preload \ Rigidity			
		N		M	
		Preload P_{ro} (N)	Rigidity R_{ao} (N/ μ m)	Preload P_{ro} (N)	Rigidity R_{ao} (N/ μ m)
706A	6	—	—	20	31
708A	8	—	—	50	51
7000A	10	65	63	170	91
7001A	12	65	63	170	91
7002A	15	75	76	210	111
7003A	17	80	82	230	122
7004A	20	90	93	330	150
7005A	25	150	117	300	152
7006A	30	180	136	360	175
7007A	35	230	160	455	205
7008A	40	245	177	490	228
7009A	45	290	193	570	247
7010A	50	310	212	615	273

Table 5-6(2) Preload and Rigidity of 72A standard series

Bearing Number	Bore d (mm)	Bearing Preload \ Rigidity			
		N		M	
		Preload P_{ro} (N)	Rigidity R_{ao} (N/ μ m)	Preload P_{ro} (N)	Rigidity R_{ao} (N/ μ m)
7200A	10	65	62	130	82
7201A	12	90	74	175	95
7202A	15	110	83	215	106
7203A	17	150	96	220	110
7204A	20	175	111	370	147
7205A	25	280	149	440	176
7206A	30	300	162	580	204
7207A	35	365	180	680	225
7208A	40	460	209	750	250
7209A	45	490	218	900	272
7210A	50	510	232	950	291

Table 5-6(3) Preload and Rigidity of BTA standard series

Bearing Number	Bore d (mm)	Bearing Preload \ Rigidity			
		M		H	
		Preload P_{ro} (N)	Rigidity R_{ao} (N/ μ m)	Preload P_{ro} (N)	Rigidity R_{ao} (N/ μ m)
BT010A	50	325	190	650	243
BT011A	55	347	212	695	272
BT012A	60	352	219	704	280
BT013A	65	421	240	841	307
BT014A	70	492	260	984	332
BT015A	75	499	268	998	343
BT016A	80	653	301	1306	384
BT017A	85	663	310	1326	396
BT018A	90	686	329	1372	421
BT019A	95	848	352	1695	449
BT020A	100	861	362	1722	463

Table 5-6(4) Preload and Rigidity of BTB standard series

Bearing Number	Bore d (mm)	Bearing Preload \ Rigidity			
		M		H	
		Preload P_{ro} (N)	Rigidity R_{ao} (N/ μ m)	Preload P_{ro} (N)	Rigidity R_{ao} (N/ μ m)
BT010B	50	540	339	1080	431
BT011B	55	576	378	1152	481
BT012B	60	582	390	1165	496
BT013B	65	697	427	1393	543
BT014B	70	815	463	1630	589
BT015B	75	826	478	1651	607
BT016B	80	1082	536	2164	681
BT017B	85	1098	553	2196	702
BT018B	90	1134	587	2269	745
BT019B	95	1404	627	2808	797
BT020B	100	1426	646	2851	821

Table 5-6(5) Preload and Rigidity of BS standard series

Bearing Number	Bore d (mm)	Bearing Preload \ Rigidity	
		N	
		Preload P_{ro} (N)	Rigidity R_{ao} (N/ μ m)
BS1747	17	2060	635
BS2047	20	2060	635
BS2562	25	3250	980
BS3062	30	3250	980
BS3572	35	3800	1130
BS4072	40	3800	1130
BS4090	40	7050	1470
BS4575	45	4200	1230
BS45100	45	8250	1720
BS50100	50	8250	1720
BS60120	60	9900	2010

6 Bearing Lubrication

The purpose of bearing lubrication is to prevent direct metal-to-metal contact between the various rolling and sliding elements. This is accomplished through the formation of a thin oil (or grease) film on contact surfaces. Lubrication also helps to reduce friction and wear, dissipate friction heat, keep away from dust. In order to achieve the above advantages and prolong the bearing life, the most effective lubrication method and lubricant has to be selected for each individual operating condition.

The machine tool spindle of keeps the amount of lubricant at minimal be no more than that

required to ensure lubricating to avoid heat generation. The relationship between oil quantity, heat generation, and bearing temperature rise is summarized in Fig.6.1.

There are several lubrication methods such as grease lubrication, oil mist lubrication, air-oil lubrication, and jet lubrication for bearings in a machine tool include. Each method has its advantages and disadvantages. It is aware that grease lubrication is being used increasingly not only because it is simple and inexpensive but also because it is environmental friendly.

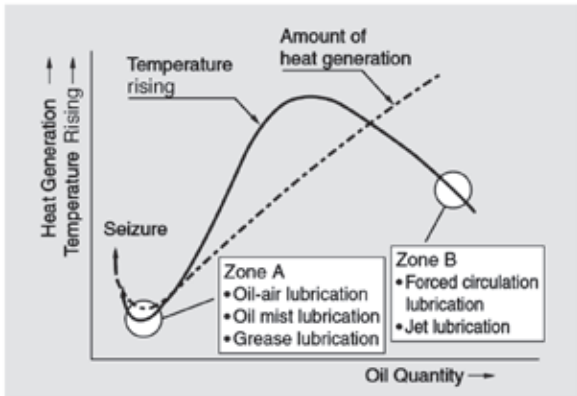

Fig. 6.1 Oil quantity, heat generation, and temperature rising

6.1 Grease Lubrication and Its Life Prediction

Lubricating grease is composed of either a mineral oil base or a synthetic oil base. To this base a thickener and other additives are added. Thickening agents are compounded with base oils to maintain the semi-solid state of the grease.

When lubricating bearings in high-speed machine tool spindle, the amount of grease supplied should be no more than that required to ensure lubricating, if the temperature is to be kept as low as possible. The following guideline for the amount of grease used for spindles is given below.

- Angular contact ball bearing: 20~25% of bearing free space. The higher speed or $d_m n$ value, the less the grease amount filled. Please consult TPI.
- Deep groove ball bearing bearing: 30% of bearing free space

The free space in a bearing typically used for main spindles are listed in precision bearing tables. One may determine the amount of grease filled accordingly.

For ball screw support applications, support bearings are generally lubricated by grease. The recommended grease is listed in Table 6.1 and amount of grease is 25% of bearing free space.

Table 6.1 Typical greases for machine tool and main spindle bearings

	Code	Thickener	Base oil	Dropping point (°C)	NLGI	Operating temperature range (°C)	Characteristics	Application
1	1K	Li	Ester+ SHC	190	2	-55~+130	General used, low torque	High speed spindle
2	12K	Li	Ester	≥ 200	2	-50~+150	Low torque	High speed ball screw support
3	15K	Ba Complex	Mineral	≥ 200	2	-40~+130	Low torque	High speed spindle
4	L559	Li	Ester	≥ 250	2	-40~+150	Anti-oxidation, long-life	High speed spindle
5	L588	Urea	Mineral	230	2	-40~+120	Anti-fretting	Low speed ball screw support
6	2AS	Li	Mineral	181	2	-25~+120	General used	Low speed ball screw support
7	L712	Polyurea	Ester+ SHC	≥ 220	2	-50~+120	Low torque high speed	High speed spindle
8	L433	Polyurea	Ester+ SHC	≥ 250	3	-40~+160	High speed, low noise	High speed motor
9	L700	Urea	Ester+ SHC	260	2	-20~+160	Wear resistance, anti-oxidation	High speed servo motor
10	L135	Ba Complex	Mineral	≥ 220	2	-20~+140	Wear resistance, Heavy loading (EP)	Ball screw support

The prediction of grease life can be calculated according to the method of Kawamura et al. The calculated life L_{50} (50% reliability life) of grease can be expressed as follows:

For urea-based grease :

$$\log L = -2.02 \times 10^{-6} \times K \times V - 2.95 \times 10^{-2} T - 8.36 F + 8.50 + K_1 \cdot$$

Where,

$$10 \leq d_m \leq 100, d_{m,n} \leq 400000, 70 \leq T \leq 180$$

For Li-based grease :

$$\log L = -1.58 \times 10^{-6} \times K \times V - 2.18 \times 10^{-2} T - 9.84 F + 6.33 + K_1 \cdot$$

Where,

$$10 \leq d_m \leq 100, d_{m,n} \leq 400000, 70 \leq T \leq 150$$

L : L_{50} grease life, hour

K : compensation factor for outer ring rotation (if inner ring rotation: $K=1$; if outer ring rotation: $K=$ inner ring rotating speed calculated from the cage orbital speed when inner ring rotation condition is assumed/ outer ring rotating speed)

V : $d_{m,n}$ value (Definition refer to 9.2)

dm : pitch diameter = $\frac{d + D}{2}$

D : outside diameter (mm)

T : bearing temperature ($^{\circ}C$)

F : load ratio P/Cr

K_1 : compensation factor for base oil type (Table 6.2, 6.3)

Table 6.2 K_1 value for urea based grease

Base oil type	compensation factor K_1
Mineral	-0.08
SHC	-0.05
Ester	-0.21
Ether	0.18
Mineral +SHC	-0.06
Mineral + Ester	-0.16
SHC+ Ester	0
SHC+ Ether	0
Ester + Ether	0.07

Table 6.3 K_1 value for Lithium based grease

Base oil type	compensation factor K_1
Mineral	-0.29
SHC	-0.05
Ester	0.42
Diester	-0.5
Silicone	0.54

6.2 Oil-mist/ Air-oil lubrication

Oil-mist lubrication is a lubricating method that transferring lubricants to oil-mist lubricants by compressing air. Air-oil lubricants is a method feeding adequate amounts of lubricants by compressing air which usually adopted through operating a volumetric piston-type distributor accurately metering the required minimum amount of lubricants and feeding it at optimal intervals controlled by a timer. The recommended oil viscosity is 10 to 32 mm^2/s .

The recommended nozzle is the one with a hole diameter of 1.0 to 1.5 mm and whose length is 4 to 6 times longer than the hole diameter. The numbers of nozzles installed on each bearing can be determined by positioning a nozzle at every 150 mm circumference of pitch circle to speculate. Table 6.4 and 6.5 shows the recommended nozzle position for different bearing types. Figure 6.2 and 6.3 shows the feed system for air-oil lubrication.

The air-oil lubrication is a lubricating method that using huge amounts of air to feed lubricants to the inside of bearings. Thus, the emission settlement of air which goes through the inside bearings is very important. If the air emission does not work smoothly, lubricants could remain inside bearings which can lead to bearings burn out. In order to increase the efficiency of air emission, the emission side has to be widened and developed with bigger air vents which can make air flow smoothly. Besides, in order to prevent lubricants from flowing back to the inside of bearings because of the change in attitude of the spindle, the shoulder dimensions of all parts should be suitably arranged. Unnecessary dimensional differences can lead to stagnation of the lubricants.

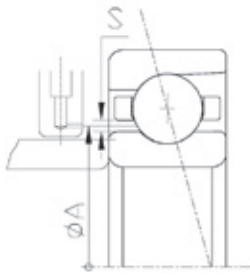

Fig. 6.2 HS type feed system for air-oil lubrication

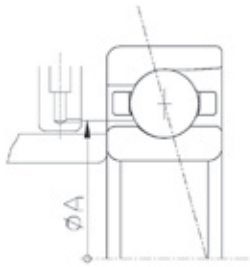

Fig. 6.3 7 type feed system for air-oil lubrication

Table 6.4 HS type air-oil/oil mist nozzle spacer dimensions

Bearing No.	S	ϕA
HS000CE1	0.5	17.7
HS001CE1	0.5	20.3
HS002CE1	0.7	23.5
HS003CE1	0.7	24.8
HS004CE1	1.2	30.1
HS005CE1	1.2	35.1
HS006CE1	1.2	39.9
HS007CE1	1.3	45.5
HS008CE1	1.3	51.0
HS009CE1	1.3	57.0
HS010CE1	1.5	61.7
HS011CE1	1.5	69.2
HS012CE1	1.5	74.2
HS013CE1	1.8	79.0
HS014CE1	2.1	86.4
HS015CE1	2.1	90.7
HS016CE1	2.1	97.9
HS017CE1	2.1	102.9
HS018CE1	2.1	110.4
HS019CE1	2.3	114.9
HS020CE1	2.3	119.8

6.3 Jet Lubrication

Oil jet is preferred for bearings having to operate at very high speed and high load. This is the most reliable lubricating technique and is typically used on the main spindle bearings of jet engines and gas turbines.

When used as a lubricating system for the main spindle of a machine tool, the amount of oil crossing the bearings also removes the heat generated by bearing operation and maintains overall temperature at acceptable levels. However, the resultant torque loss is great, as a large amount of oil which is low viscosity oil (ISO standards VG10 or VG15) is supplied to each bearing.

7 Bearing Limiting Speed

7.1 Bearing Limiting Speed

Angular contact ball bearings feature the highest rotational speed capabilities of all precision bearings. The limiting speeds listed in the precision bearing tables are guideline values. They are based on a single bearing that is lightly spring preloaded and subject to both grease and air-oil lubrication. In situations where the lubricant is used as a mean to remove heat, higher speed can be achieved. Limiting temperature for grease-lubricated bearings is lower than that for oil because of greater lubricant deterioration. Therefore, limiting speed for grease lubrication is consequently about 75% of the value achievable with oil.

Achievement of maximum speed is affected by internal configuration and correct assembly of the bearings. For bearing internal configuration, bearing arrangement, preload, bearing precision, contact angle and way of lubrication may influence bearing speed. Also, tolerance limits of shaft, housing, and spindle components, proper dynamic balancing of rotating parts, and efficient lubrication are external.

Accordingly, the limiting speed calculation can be performed based on the above consideration and the speed n_{max} is calculated as follows:

$$n_{max} = f_1 \cdot f_2 \cdot f_3 \cdot n_L \text{ (min}^{-1}\text{)}$$

where, f_1 : Speed factor for bearing arrangement v.s. preload, refer to Table 7.1

f_2 : Speed factor for bearing precision, refer to Table 7.2

f_3 : Speed factor for contact angle, refer to Table 7.3

n_L : The limiting speed for grease and oil lubrications, refer to Precision Bearing Tables

Table 7.1 Speed factor for bearing with various arrangements and preload f_1

Bearing arrangement		L	N	M	H
	DB	0.80	0.75	0.65	0.50
		/	/	/	/
	DBT	0.85	0.80	0.70	0.55
		/	/	/	/
	DTBT	0.65	0.60	0.50	0.30
		/	/	/	/
	DTBT	0.75	0.70	0.55	0.40
		/	/	/	/
	DTBT	0.70	0.65	0.50	0.30
		/	/	/	/
	DTBT	0.80	0.75	0.60	0.45
		/	/	/	/

Table 7.2 Speed factor for bearing precision f_2

Precision	Factor for precision		
	P2	P4	P5
f_2	1.1	1.0	0.9

Table 7.3 Speed factor for contact angle f_3

Contact angle	Factor for contact angle			
	15°	18°	25°	30°
f_3	1.00	0.97	0.86	0.73

When a ceramic ball is used, limiting speed value will be 1.25 times the value of steel ball. If the ball guided polyamide resin cage is used, the limiting speed is limited to 1.4 million $d_m n$ values.

The limiting speed for ball screw support BS thrust bearings is different from that for angular contact ball bearings. It accounts for the discrepancy for contact angle and preload between two types of bearings. The speed factor of limiting speed n_{max} for BS bearings are listed in Table 7.4

Table 7.4 Speed factors for BS bearings f_1, f_2, f_3

Arrangement	DF DB	DFT DBT	DTFT DTBT
f_1	0.58	0.41	0.49
Precision	P4		P5
f_2	1.0		0.9
Contact angle	60°		
f_3	1.00		

Same as BS bearings, high-speed thrust BT bearings have their own limiting speed calculation. The speed factor of limiting speed n_{max} for BT DB combined bearings are listed in Table 7.5 & 7.6

Table 7.5 Speed factors for BT DB combined bearings f_1, f_2

Preload	M	H
f_1	1.0	0.85
Precision	P4	P5
f_2	1.0	

Table 7.6 Speed factor for BT DB bearing contact angle f_3

Contact angle	30°	40°
f_3	1.00	0.86

8 Bearing Handling

8.1 Cleaning and Filling with Grease

Handling the precision rolling bearing correctly is a vital step to achieve maximum speed and limited temperature rise. The handling of bearings involves cleaning, drying, filling with grease (if necessary), and the running-in operation.

For each step, please take precaution and follow the below description:

The cleaning step removes the rust-preventive oil. First, immerse the bearing in kerosene or a highly volatile solvent such as naphthosol. Wash the bearing carefully by hand and then remove the kerosene using benzene or alcohol. Use clean compressed air to blow away the rinsing fluid. (After cleaning, coating the bearing with the lubricant to be used or less viscous oil for jet-oil lubrication, or immersing the bearing in lubricant or other low-viscosity oil is recommended.)

If the bearing is to be used with grease lubrication, the bearing should be dried thoroughly to avoid leakage of grease. Fill the bearing with grease immediately after drying. Drying can be achieved by blowing hot air onto the bearing or placing the bearing in a chamber at constant temperature. When drying with hot air, please make sure the air is clean.

For greasing ball and roller bearings please refer to the procedure shown below. For ball bearings, use an injector or small plastic bag, aiming at the inner ring rolling surface, and carefully apply grease between balls in equal amounts. For bearings with ring-guided cage, also apply grease to the guide surface of the cage using a spatula or similar tool. If grease cannot be added into the inner ring raceway due to the small gap between the cage and the inner ring, add grease to the outer ring raceway. In this case, turn the bearing so that the grease is fully spread on the inner ring side.

For roller bearings, apply grease to the outer or inner side of rollers, while turning the rollers to spread the grease to the opposite side. If a lump of grease remains on the outer face of cage rib, the running-in operation may take a longer time

8.2 Running In

For oil lubrication, the running-in operation is relatively simple with oil lubrication because no peak temperature occurs and the bearing temperature stabilizes within a relatively short time. TPI recommends that the speed of bearing is to be increased in steps of 2000 to 3000 min^{-1} until the maximum speed is reached. Every speed setting should be maintained for about 30 minutes. However, for the speed range where the $d_m n$ (pitch circle diameter across rolling elements multiplied

by speed) exceeds 1,000,000, increase the bearing speed in steps of 1000 to 2000 min^{-1} to ensure the stable running.

For a grease-lubricated bearing, a running-in operation is very important in attaining stable temperature rise. During a running-in operation, a large temperature rise (peak) occurs while the bearing speed is increased, and then the bearing temperature eventually stabilizes. Before temperature stabilization, a certain lead-time will be needed. For ball bearing, TPI recommends that the bearing speed be increased in steps of 1000 to 2000 min^{-1} and be further increased only after the temperature has stabilized at the current speed setting. However, for the speed range where the $d_m n$ exceeds 400,000, increase the bearing speed in steps of 500 to 1000 min^{-1} to ensure the stable running. Compared with contact ball bearings, the time to peak temperature or saturation in running-in operation of roller bearings tends to be longer. Also, there will be temperature rise due to whipping of the grease and the temperature rise may be unstable. To cope with this problem, run the roller bearing in the maximum speed range for a prolonged period.

Increase the bearing speed in steps of 500 to 1000 min^{-1} only after the bearing temperature has stabilized at the current speed setting. For the speed range where the $d_m n$ exceeds 300,000, increase the bearing speed in steps of 500 min^{-1} to ensure safety.

As shown in Fig.8.1, bearing speed is increased gradually in steps. As soon as the temperature becomes saturated at each speed setting, the speed is increased to the next step.

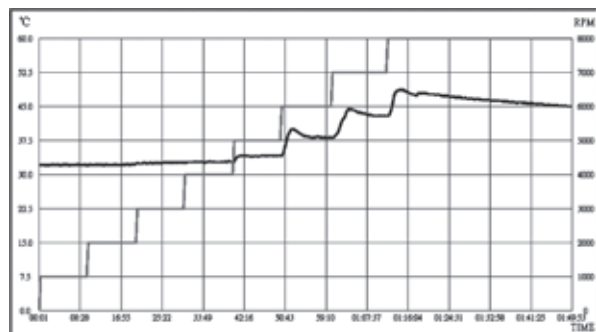

Fig. 8.1 The bearing speed is gradually increased in steps

8.3 Mounting

There are several mounting techniques such as press fitting with hydraulic press, heating bearings with heater, and cool-shrinking shaft with liquid nitrogen. It is essential to minimize the adverse effects caused by mounting and maintain bearing accuracy.

If press-fitting a bearing with a hydraulic press is chosen, the press-fitting force due to the interference between the shaft and inner ring must be calculated. Next, using an inner ring press-

fitting jig, the inner ring is correctly press-fitted to the shoulder of shaft. Please be careful not to exert a force on the outer ring.

For spindle applications, precision bearings are tightly fitted with a shaft. Induction heater is frequently used to heat the bearing bore and mount to the shaft correctly in position and instantly before shrinking back the original size. According to the thermal expansion coefficient 12.5×10^{-6} , it is easy to calculate interference fit $\delta = 12.5 \times 10^{-6} \times \phi d \times \Delta T$, where ΔT is heating temperature minus room temperature and ϕd is inner ring bore diameter. In reality, the low temperature shaft tends to lower the bearing and causes it to shrink during mounting. It is suggested that the heating temperature to be set is more than calculated temperature. If a bearing has resin cage, the suggested temperature need s to be 80°C or less.

When the bearing temperature drops to room temperature, the inner ring will shrink axially, and there will be a gap between the bearing side face and shaft shoulder illustrated in Fig. 8.2. For this reason, push the bearing and shaft together with a press until the unit returns to normal temperature. After cooling, check that the bearing is mounted to the shaft correctly.

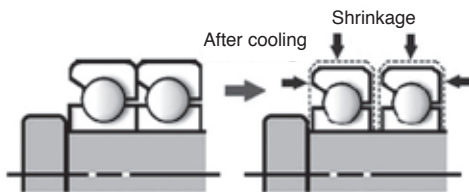

Fig. 8.2 Cooling after mounting by heating bearings

8.4 Tightening of Inner and Outer Ring

In order to mount and secure a bearing to a main spindle when it rotates, the inner ring side face is usually clamped with a precision bearing nut, and the front cover situated on the outer ring side face is bolted down.

Tightening with a precision bearing nut (precision locknut) provides a predetermined tightening force by controlling the bearing torque shown in Fig 8.3. When locking the bearing with a precision bearing nut, make sure that the squareness between the bearing surface and the shaft centerline is 3 μm or less so that adequate bearing accuracies are maintained.

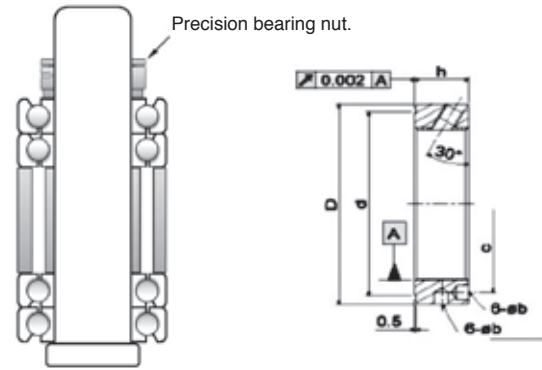

Fig. 8.3 Tightening with precision bearing nut

Because the thread face of the precision bearing nut, the thread face of the shaft and the bearing surface and nut constitute sliding surfaces, the correlation between tightening torque and tightening force will vary depending on the friction coefficient. The nut tightening force refer to Table 8.1. Therefore, the nut needs to be thoroughly run on the shaft thread in advance to ensure smooth and uniform tightening. It is also necessary to determine the correlation between tightening torque and tightening force by using a load washer or force device.

As shown in Fig. 8.4, the gap for front cover pressing allowance may vary depending upon its bearing bore diameter. The front cover is assembled by utilizing bolt holes (6 to 8 positions) on its flange. Too much gap on the outer ring or a smaller number of fastening bolts may deteriorate the roundness of the bearing ring. It is suggested by TPI that:

- Bearing bore $d \leq 100\text{mm}$, the gap is 0.01-0.03mm ;
- Bearing bore $d \geq 100\text{mm}$, the gap is 0.02-0.04mm ;

Table 8.1 Nut tightening force

Bearing bore (mm)	Nut tightening force (N)	Front cover drive-up (mm)
20-35	2940~4900	0.01~0.02
40-50	4900~9800	
55-75	9800~14700	
80-130	14700~24500	0.02~0.04
140-200	24500~34300	
220-300	34300~44100	

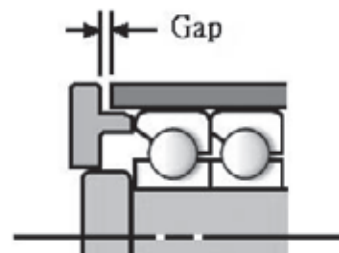
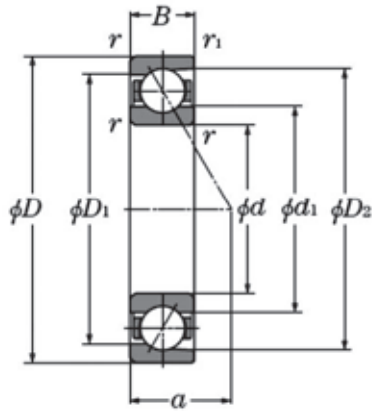

Fig. 8.4 Front cover pressing allowance or gap

Angular Contact Ball Bearings

70C Series



Dynamic equivalent radial load
 $P_r = X F_r + Y F_a$

Normal Contact Angle	$i f_0 F_a^*$ C_{or}	e	Single, DT				DB or DF				
			$F_r/F_a \leq e$		$F_r/F_a > e$		$F_r/F_a \leq e$		$F_r/F_a > e$		
			X	Y	X	Y	X	Y	X	Y	
15	0.178	0.38	1	0	0.44	1	1.47	1	1.65	0.72	2.39
	0.357	0.4					1.4		1.57		2.28
	0.714	0.43					1.3		1.46		2.11
	1.07	0.46					1.23		1.38		2
	1.43	0.47					1.19		1.34		1.93
	2.14	0.5					1.12		1.26		1.82
	3.57	0.55					1.02		1.14		1.66
	5.35	0.56					1		1.12		1.63
18	0.57	1	0	0.43	1	1	1.09	0.7	1.63		
25	0.68	1	0	0.41	0.87	1	0.92	1.67	1.41		
30	0.8	1	0	0.39	0.76	1	0.78	1.63	1.24		
40	1.14	1	0	0.35	0.57	1	0.55	0.57	0.93		
50	1.49			0.73	1	1.37	0.57	0.73			
55	1.79			0.81	1	1.6	0.56	0.81			
60	2.17			0.92	1	1.9	0.55	0.92			

For i, use 2 for DB, DF and 1 for DT
 where X: Radial load factor
 Y: Axial load factor

d 10~100mm

Boundary Dimensions (mm)					Basic Load Ratings				Static Axial Load Capacity		Bearing ^② Numbers Type
d	D	B	r ^①	r_1 ^①	Dynamic		Static		(KN)	(Kgf)	
			min	min	C_r (KN)	C_r (Kgf)	C_{or} (KN)	C_{or} (Kgf)			
8	22	7	0.3	0.15	3.50	355	1.50	153	1.29	132	708C
10	26	8	0.3	0.15	5.30	540	2.45	250	4.50	450	7000C*
12	28	8	0.3	0.15	5.40	555	2.63	269	5.25	540	7001C
15	32	9	0.3	0.15	6.20	635	3.35	345	6.35	650	7002C
17	35	10	0.3	0.15	6.55	670	3.80	390	5.90	605	7003C
20	42	12	0.6	0.3	11.1	1130	6.55	670	10.2	1040	7004C
25	47	12	0.6	0.3	11.7	1190	7.40	755	11.2	1140	7005C
30	55	13	1.0	0.6	15.1	1540	10.3	1050	15.7	1600	7006C
35	62	14	1.0	0.6	19.1	1950	13.7	1400	20.6	2100	7007C
40	68	15	1.0	0.6	20.6	2100	15.9	1620	22.5	2300	7008C
45	75	16	1.0	0.6	24.4	2490	19.3	1970	27.9	2850	7009C
50	80	16	1.0	0.6	26.0	2650	21.9	2230	31.0	3200	7010C
55	90	18	1.1	0.6	34.0	3500	28.6	2900	40.5	4150	7011C
60	95	18	1.1	0.6	35.0	3600	30.0	3100	43.0	4400	7012C
65	100	18	1.1	0.6	37.0	3800	34.0	3500	47.5	4850	7013C
70	110	20	1.1	0.6	47.0	4800	43.0	4400	65.0	6640	7014C
75	115	20	1.1	0.6	48.0	4900	45.5	4650	65.5	6700	7015C
80	125	22	1.1	0.6	58.5	6000	55.5	5650	79.0	8100	7016C
85	130	22	1.1	0.6	60.0	6150	58.5	6000	83.0	8500	7017C
90	140	24	1.5	1.1	71.5	7300	69.0	7000	101	10300	7018C
95	145	24	1.5	1.1	73.5	7500	73.0	7450	103	10500	7019C*
100	150	24	1.5	1.1	75.5	7700	77.0	7900	118	11400	7020C

① Minimum allowable dimension for chamfer dimension r or r₁

② Bearings with * mark are not available and could be supplied on request

③ All limiting speeds of bearing already consider speed factor for contact angle f₃

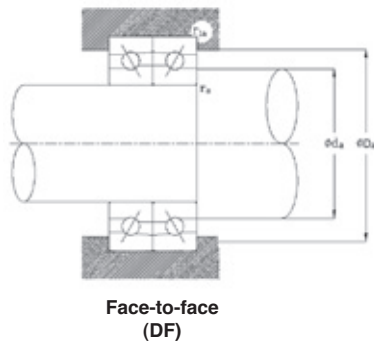
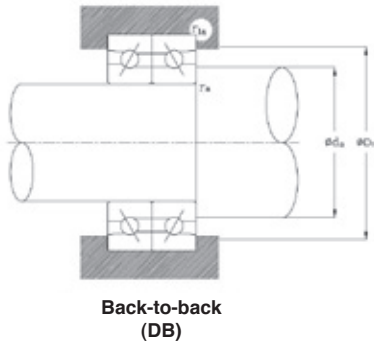

Static equivalent radial load $P_{or} = X_o F_r + Y_o F_a$

Contact Angle	Single DT		DB or DF	
	X_o	Y_o	X_o	Y_o
15	0.5	0.46	1	0.92
18	0.5	0.42	1	0.84
25	0.5	0.38	1	0.76
30	0.5	0.33	1	0.66
40	0.5	0.26	1	0.52

where P_{or} : Static equivalent radial load(N)
 F_r : Radial load(N)
 F_a : Axial load(N)
 X_o : Static radial load factor
 Y_o : Static axial load factor

Factor	Load Center (mm)	Limiting Speeds n_L (min ⁻¹) ③		Reference Dimensions			Abutment and Dimensions (mm)					Space Capacity (cm ³)	Weight (kg)
		Grease	Oil	d_1	D_1	D_2	d_a min	D_a max	D_b max	r_a max	r_{1a} max	Open (Approx)	Open (Approx)
9.4	5.5	77000	117000	12.8	17.5	19.1	10.5	19.5	—	0.3	—	0.8	0.012
12.6	6.0	63900	97300	15.4	20.6	22.9	12.5	23.5	24.8	0.3	0.15	0.9	0.019
13.4	6.5	57500	87500	18.1	22.6	25.4	14.5	25.5	26.8	0.3	0.15	1.0	0.021
14.1	7.5	49000	74500	21.1	26.1	28.5	17.5	29.5	30.8	0.3	0.15	1.3	0.030
14.5	8.5	44300	67400	23.4	28.6	31.0	19.5	32.5	33.8	0.3	0.15	1.8	0.037
14.0	10.0	37100	56500	27.5	34.5	37.7	24.5	37.5	39.5	0.6	0.3	2.9	0.067
14.7	11.0	32000	48700	32.5	39.5	42.7	29.5	42.5	44.5	0.6	0.3	3.3	0.079
14.9	12.0	27100	41200	38.6	46.4	50.0	35.5	49.5	50.5	1.0	0.6	4.8	0.11
15.0	13.5	23800	36100	44.2	52.8	56.9	40.5	56.5	57.5	1.0	0.6	6.3	0.15
15.4	15.0	21300	32500	49.6	58.3	62.4	45.5	62.5	63.5	1.0	0.6	7.4	0.19
15.4	16.0	19200	29200	55.2	64.8	69.2	50.5	69.5	70.5	1.0	0.6	9.4	0.24
15.6	16.0	17700	27000	60.2	69.8	74.2	55.5	74.5	75.5	1.0	0.6	11	0.26
15.5	19.0	15900	24200	66.8	78.1	83.4	62	83	85.5	1.0	0.6	16	0.38
15.6	19.5	14900	22600	71.8	83.1	88.4	67	88	90.5	1.0	0.6	17	0.41
15.9	20.0	14000	21300	76.8	88.1	93.4	72	93	95.5	1.0	0.6	18	0.44
15.7	22.0	12800	19500	83.6	96.4	102.5	77	103	105.5	1.0	0.6	24	0.61
15.9	23.0	12200	18500	88.5	101.5	107.5	82	108	110.5	1.0	0.6	26	0.64
15.7	25.0	11300	17100	95.1	109.9	116.7	87	118	120.5	1.0	0.6	34	0.86
15.9	25.0	10700	16300	100.1	114.9	121.7	92	123	125.5	1.0	0.6	36	0.90
15.7	27.0	10000	15300	106.8	123.2	130.8	98.5	131.5	134.5	1.5	1.0	47	1.17
15.9	28.0	9600	14600	111.7	128.2	135.8	103.5	136.5	139.5	1.5	1.0	49	1.22
16.0	29.0	9200	14000	116.8	133.2	140.8	108.5	141.5	144.5	1.5	1.0	51	1.27

Angular Contact Ball Bearings

70AD Series

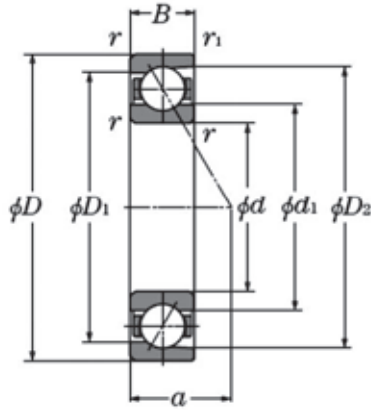

Dynamic equivalent radial load
 $P_r = X F_r + Y F_a$

Normal Contact Angle	$i f_0 F_a^*$ C_{or}	e	Single, DT				DB or DF			
			$F_r/F_a \leq e$		$F_r/F_a > e$		$F_r/F_a \leq e$		$F_r/F_a > e$	
			X	Y	X	Y	X	Y	X	Y
15	0.178	0.38				1.47		1.65		2.39
	0.357	0.4				1.4		1.57		2.28
	0.714	0.43				1.3		1.46		2.11
	1.07	0.46			0.44	1.23		1.38	0.72	2
	1.43	0.47	1	0		1.19	1	0.34		1.93
	2.14	0.5				1.12		0.26		1.82
	3.57	0.55				1.02		1.14		1.66
	5.35	0.56				1		1.12		1.63
	18	0.57			0.43	1	1	1.09	0.7	1.63
	25	0.68	1	0	0.41	0.87	1	0.92	1.67	1.41
30	0.8	1	0	0.39	0.76	1	0.78	1.63	1.24	
40	1.14	1	0	0.35	0.57	1	0.55	0.57	0.93	
50	1.49			0.73	1	1.37	0.57	0.73		
55	1.79			0.81	1	1.6	0.56	0.81		
60	2.17			0.92	1	1.9	0.55	0.92		

For i, use 2 for DB, DF and 1 for DT
 where X: Radial load factor
 Y: Axial load factor

d 10~100mm

Boundary Dimensions (mm)					Basic Load Ratings				Static Axial Load Capacity		Bearing ^② Numbers Type
d	D	B	$r^{①}$ min	$r_1^{①}$ min	Dynamic		Static		(KN)	(Kgf)	
					C_r (KN)	C_r (Kgf)	C_{or} (KN)	C_{or} (Kgf)			
10	26	8	0.3	0.15	5.10	520	2.41	246	2.33	238	7000AD*
12	28	8	0.3	0.15	5.20	530	2.53	258	3.10	318	7001AD*
15	32	9	0.3	0.15	5.95	605	3.20	330	3.75	385	7002AD*
17	35	10	0.3	0.15	6.30	640	3.60	370	3.90	400	7003AD*
20	42	12	0.6	0.3	10.5	1080	6.25	640	7.55	770	7004AD*
25	47	12	0.6	0.3	11.0	1130	7.05	720	8.20	840	7005AD
30	55	13	1.0	0.6	14.4	1470	9.80	1000	11.5	1180	7006AD
35	62	14	1.0	0.6	18.2	1860	13.0	1330	14.1	1440	7007AD
40	68	15	1.0	0.6	19.5	1990	15.1	1540	16.4	1680	7008AD*
45	75	16	1.0	0.6	23.0	2350	18.2	1860	20.6	2100	7009AD*
50	80	16	1.0	0.6	24.6	2510	20.7	2120	23.1	2360	7010AD
55	90	18	1.1	0.6	32.0	3300	27.1	2770	30.0	3100	7011AD
60	95	18	1.1	0.6	33.0	3350	29.1	2970	31.0	3200	7012AD
65	100	18	1.1	0.6	35.0	3550	32.0	3300	33.0	3400	7013AD
70	110	20	1.1	0.6	44.0	4500	40.5	4150	42.0	4300	7014AD
75	115	20	1.1	0.6	45.0	4600	43.0	4400	47.0	4800	7015AD
80	125	22	1.1	0.6	55.5	5650	52.0	5350	58.5	5950	7016AD
85	130	22	1.1	0.6	56.5	5800	55.5	5650	61.0	6200	7017AD
90	140	24	1.5	1.1	67.5	6900	65.5	6650	75.0	7650	7018AD
95	145	24	1.5	1.1	69.5	7050	69.0	7050	77.5	7900	7019AD*
100	150	24	1.5	1.1	71.0	7250	73.0	7450	82.5	8450	7020AD

- ① Minimum allowable dimension for chamfer dimension r or r₁
- ② Bearings with * mark are not available and could be supplied on request
- ③ All limiting speeds of bearing already consider speed factor for contact angle f₃

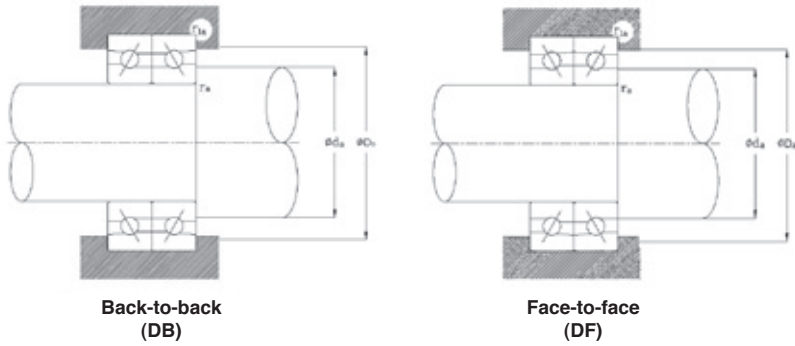

Static equivalent radial load $P_{or} = X_o F_r + Y_o F_a$

Contact Angle	Single DT		DB or DF	
	X_o	Y_o	X_o	Y_o
15	0.5	0.46	1	0.92
18	0.5	0.42	1	0.84
25	0.5	0.38	1	0.76
30	0.5	0.33	1	0.66
40	0.5	0.26	1	0.52

where P_{or} : Static equivalent radial load(N)
 F_r : Radial load(N)
 F_a : Axial load(N)
 X_o : Static radial load factor
 Y_o : Static axial load factor

Load Center (mm)	Limiting Speeds n_L (min ⁻¹) ^③		Reference Dimensions			Abutment and Dimensions (mm)					Space Capacity (cm ³)	Weight (kg)
	Grease	Oil	d_1	D_1	D_2	d_a min	D_a max	D_b max	r_a max	r_{1a} max	Open (Approx)	Open (Approx)
8.2	55000	84700	15.4	20.6	22.7	12.5	23.5	24.8	0.3	0.15	0.9	0.019
8.8	49500	76100	18	22.9	25.2	14.5	25.5	26.8	0.3	0.15	1.0	0.021
10.0	42100	64800	21.1	25.9	28.2	17.5	29.5	30.8	0.3	0.15	1.3	0.030
11.1	38100	58600	23.4	29	30.7	19.5	32.5	33.8	0.3	0.15	1.8	0.037
12.2	31900	49200	27.5	34.5	37.3	24.5	37.5	39.5	0.6	0.3	2.9	0.067
14.4	27500	42400	32.5	39.5	42.3	29.5	42.5	44.5	0.6	0.3	3.3	0.079
15.9	23300	35800	38.6	46.4	49.5	35.5	49.5	50.5	1.0	0.6	4.8	0.11
17.8	20500	31400	44.2	52.8	56.3	40.5	56.5	57.5	1.0	0.6	6.3	0.15
19.6	18300	28300	49.6	58.3	61.8	45.5	62.5	63.5	1.0	0.6	7.4	0.19
21.5	16500	25400	55.2	64.8	68.6	50.5	69.5	70.5	1.0	0.6	9.4	0.24
23.2	15200	23500	60.2	69.8	73.6	55.5	74.5	75.5	1.0	0.6	11	0.26
25.9	13700	21100	66.8	78.1	82.7	62	83	85.5	1.0	0.6	16	0.38
27.1	12800	19700	71.8	83.1	87.6	67	88	90.5	1.0	0.6	17	0.41
28.2	12000	18500	76.8	88.1	92.6	72	93	95.5	1.0	0.6	18	0.44
31.0	11000	17000	83.6	96.4	101.7	77	103	105.5	1.0	0.6	24	0.61
22.1	10500	16100	88.5	101.5	106.7	82	108	110.5	1.0	0.6	26	0.64
34.9	9700	14900	95.1	109.9	115.8	87	118	120.5	1.0	0.6	34	0.86
36.1	9200	14200	100.1	114.9	120.8	92	123	125.5	1.0	0.6	36	0.90
38.8	8600	13300	106.8	123.2	129.8	98.5	131.5	134.5	1.5	1.0	47	1.17
40.0	8300	12700	111.7	128.2	134.8	103.5	136.5	139.5	1.5	1.0	49	1.22
41.1	7900	12200	116.8	132.2	139.8	108.5	141.5	144.5	1.5	1.0	51	1.27

Angular Contact Ball Bearings

72C Series

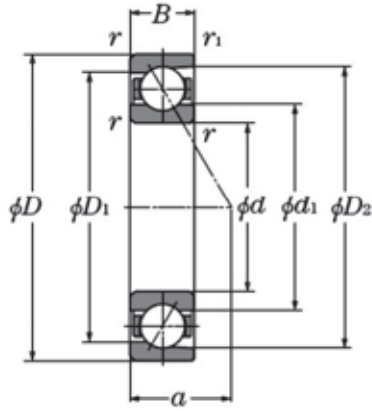

Dynamic equivalent radial load
 $P_r = X F_r + Y F_a$

Normal Contact Angle	$i f_0 F_a^*$ C_{or}	e	Single, DT				DB or DF			
			$F_r/F_a \leq e$		$F_r/F_a > e$		$F_r/F_a \leq e$		$F_r/F_a > e$	
			X	Y	X	Y	X	Y	X	Y
15	0.178	0.38	1	0	0.44	1	1.47	1.65	0.72	2.39
	0.357	0.4					1.4	1.57		2.28
	0.714	0.43					1.3	1.46		2.11
	1.07	0.46					1.23	1.38		2
	1.43	0.47					1.19	1.34		1.93
	2.14	0.5					1.12	1.26		1.82
	3.57	0.55					1.02	1.14		1.66
	5.35	0.56					1	1.12		1.63
	18	0.57					1	0		0.43
25	0.68	1	0	0.41	0.87	1	0.92	1.67	1.41	
30	0.8	1	0	0.39	0.76	1	0.78	1.63	1.24	
40	1.14	1	0	0.35	0.57	1	0.55	0.57	0.93	
50	1.49			0.73	1	1.37	0.57	0.73		
55	1.79			0.81	1	1.6	0.56	0.81		
60	2.17			0.92	1	1.9	0.55	0.92		

For i, use 2 for DB, DF and 1 for DT
 where X: Radial load factor
 Y: Axial load factor

d 10~100mm

Boundary Dimensions (mm)					Basic Load Ratings				Static Axial Load Capacity		Bearing ^② Numbers Type
d	D	B	r ^①	r_1 ^①	Dynamic		Static		(KN)	(Kgf)	
			min	min	C_r (KN)	C_r (Kgf)	C_{or} (KN)	C_{or} (Kgf)			
10	30	9	0.6	0.3	5.40	555	2.63	269	1.01	103	7200C*
12	32	10	0.6	0.3	7.05	720	3.45	355	1.58	162	7201C
15	35	11	0.6	0.3	8.95	915	4.50	460	1.89	193	7202C
17	40	12	0.6	0.3	11.1	1140	5.75	590	2.66	272	7203C
20	47	14	1.0	0.6	14.6	1490	8.15	835	3.65	375	7204C
25	52	15	1.0	0.6	16.5	1690	10.3	1050	3.75	385	7205C
30	62	16	1.0	0.6	23.0	2350	14.7	1500	7.10	725	7206C
35	72	17	1.1	0.6	30.0	3100	19.9	2030	10.6	1090	7207C
40	80	18	1.1	0.6	36.0	3700	25.2	2570	14.4	1470	7208C
45	85	19	1.1	0.6	40.5	4150	28.8	2940	14.8	1510	7209C
50	90	20	1.1	0.6	42.5	4350	31.5	3250	15.3	1560	7210C
55	100	21	1.5	1.0	52.5	5400	40.0	4100	21.5	2200	7211C*
60	110	22	1.5	1.0	64.0	6550	49.5	5050	26.0	2660	7212C*
65	120	23	1.5	1.0	69.5	7100	54.5	5600	28.5	2910	7213C*
70	125	24	1.5	1.0	76.0	7750	60.0	6150	30.5	3150	7214C*
75	130	25	1.5	1.0	79.0	8100	65.5	6700	33.0	3400	7215C*
80	140	26	2.0	1.0	92.5	9450	77.0	7900	34.5	3550	7216C*
85	150	28	2.0	1.0	103	10600	90.0	9200	46.5	4750	7217C*
90	160	30	2.0	1.0	122	12500	104	10700	53.0	5450	7218C*
95	170	32	2.1	1.1	139	14200	119	12200	62.0	6350	7219C*
100	180	34	2.1	1.1	149	15200	126	12900	66.5	6800	7220C*

- ① Minimum allowable dimension for chamfer dimension r or r₁
- ② Bearings with * mark are not available and could be supplied on request
- ③ All limiting speeds of bearing already consider speed factor for contact angle f₃

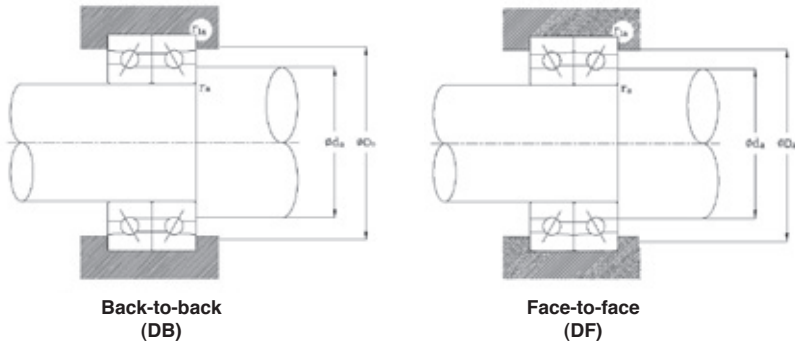

Static equivalent radial load $P_{or} = X_o F_r + Y_o F_a$

Contact Angle	Single DT		DB or DF	
	X_o	Y_o	X_o	Y_o
15	0.5	0.46	1	0.92
18	0.5	0.42	1	0.84
25	0.5	0.38	1	0.76
30	0.5	0.33	1	0.66
40	0.5	0.26	1	0.52

where P_{or} : Static equivalent radial load(N)
 F_r : Radial load(N)
 F_a : Axial load(N)
 X_o : Static radial load factor
 Y_o : Static axial load factor

Factor	Load Center (mm)	Limiting Speeds n_L (min ⁻¹) ^③		Reference Dimensions			Abutment and Dimensions (mm)					Space Capacity (cm ³)	Weight (kg)
		Grease	Oil	d_1	D_1	D_2	d_a min	D_a max	D_b max	r_a max	r_{1a} max	Open (Approx)	Open (Approx)
13.2	7.0	42900	55600	17.4	23.0	26.2	14.5	25.5	27.5	0.6	0.3	0.9	0.029
12.9	8.0	40000	51800	18.7	25.7	28.2	16.5	27.5	29.5	0.6	0.3	1.3	0.036
12.9	9.0	35200	45600	21.7	28.7	31.3	19.5	30.5	32.5	0.6	0.3	1.5	0.045
13.0	10.0	30500	39600	24.8	32.7	35.7	21.5	35.5	37.5	0.6	0.3	2.1	0.062
13.2	11.5	25500	33000	29.2	38.5	41.9	25.5	41.5	42.5	1.0	0.6	3.1	0.10
14.0	13.0	22600	29200	34.2	43.5	47.0	30.5	46.5	47.5	1.0	0.6	4.1	0.12
14.0	14.0	18900	24500	40.8	52.0	56.0	35.5	56.5	57.5	1.0	0.6	6.6	0.19
14.0	16.0	16400	21300	47.4	60.5	65.2	42	65	67.5	1.0	0.6	8.8	0.27
14.2	17.0	14700	19000	53.5	67.5	72.4	47	73	75.5	1.0	0.6	11	0.35
14.3	18.0	13500	17500	58.1	73.0	78.4	52	78	80.5	1.0	0.6	14	0.40
14.6	19.0	12600	16300	63.1	78.0	82.5	57	83	85.5	1.0	0.6	17	0.45
14.5	21.0	11400	14700	69.7	86.5	91.5	63.5	91.5	94.5	1.5	1.0	21	0.59
14.4	22.0	10200	13200	76.3	95.0	100.5	68.5	101.5	104.5	1.5	1.0	28	0.76
14.6	24.0	9500	12300	83.4	103.0	109.5	73.5	111.5	114.5	1.5	1.0	34	0.95
14.6	25.0	9000	11700	87.9	108.5	114.5	78.5	116.5	119.5	1.5	1.0	40	1.04
14.8	26.0	8500	11000	92.9	113.5	119.6	83.5	121.5	124.5	1.5	1.0	43	1.14
14.8	28.0	8000	10400	99.6	121.9	128.6	90	130	134.5	2.0	1.0	54	1.39
14.8	30.0	7500	9700	106.2	130.5	137.7	95	140	144.5	2.0	1.0	63	1.73
14.6	32.0	7000	9100	112.9	138.9	146.7	100	150	154.5	2.0	1.0	80	2.13
14.6	34.0	6600	8600	119.5	147.4	155.8	107	158	163	2.0	1.0	96	2.58
14.6	36.0	6300	8100	126.2	155.9	164.8	112	168	173	2.0	1.0	119	3.21

Angular Contact Ball Bearings

HS CE1 Series

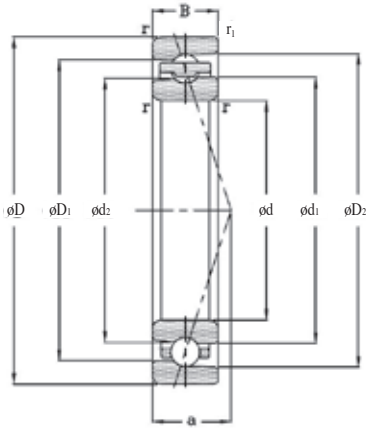

Dynamic equivalent radial load
 $P_r = X F_r + Y F_a$

Normal Contact Angle	$i f_0 F_a^*$ C_{or}	e	Single, DT				DB or DF				
			$F_r/F_a \leq e$		$F_r/F_a > e$		$F_r/F_a \leq e$		$F_r/F_a > e$		
			X	Y	X	Y	X	Y	X	Y	
15	0.178	0.38				1.47		1.65		2.39	
	0.357	0.4				1.4		1.57		2.28	
	0.714	0.43				1.3		1.46		2.11	
	1.07	0.46				1.23		1.38		2	
	1.43	0.47	1	0	0.44	1.19	1	0.34	0.72	1.93	
	2.14	0.5				1.12		0.26		1.82	
	3.57	0.55				1.02		1.14		1.66	
	5.35	0.56				1		1.12		1.63	
18	0.57			1	0	0.43	1	1	1.09	0.7	1.63
25	0.68			1	0	0.41	0.87	1	0.92	1.67	1.41
30	0.8			1	0	0.39	0.76	1	0.78	1.63	1.24
40	1.14			1	0	0.35	0.57	1	0.55	0.57	0.93
50	1.49					0.73	1	1.37	0.57	0.73	
55	1.79					0.81	1	1.6	0.56	0.81	
60	2.17					0.92	1	1.9	0.55	0.92	

For i, use 2 for DB, DF and 1 for DT
 where X: Radial load factor
 Y: Axial load factor

d 10~100mm

Boundary Dimensions (mm)					Basic Load Ratings				Static Axial Load Capacity		Bearing Numbers Type
d	D	B	r ①	r_1 ①	Dynamic		Static		(KN)	(Kgf)	
			min	min	C_r (KN)	C_r (Kgf)	C_{or} (KN)	C_{or} (Kgf)			
10	26	8	0.3	0.15	2.07	212	1.57	160	2.00	204	HS000CE1*
12	28	8	0.3	0.15	2.06	210	1.59	163	2.06	210	HS001CE1*
15	32	9	0.3	0.15	2.85	291	2.40	245	3.05	315	HS002CE1*
17	35	10	0.3	0.15	2.92	298	2.60	265	3.30	340	HS003CE1
20	42	12	0.6	0.3	4.70	480	4.50	460	5.75	590	HS004CE1
25	47	12	0.6	0.3	4.80	490	4.90	500	6.25	640	HS005CE1
30	55	13	1.0	0.6	10.4	1070	10.0	1020	12.8	1310	HS006CE1
35	62	14	1.0	0.6	12.9	1320	12.7	1300	16.2	1660	HS007CE1
40	68	15	1.0	0.6	13.7	1400	14.5	1480	18.6	1900	HS008CE1
45	75	16	1.0	0.6	14.4	1470	16.2	1660	20.8	2130	HS009CE1
50	80	16	1.0	0.6	17.5	1790	20.1	2050	25.8	2630	HS010CE1
55	90	18	1.1	0.6	18.7	1910	24.4	2490	30.0	3100	HS011CE1*
60	95	18	1.1	0.6	19.0	1940	24.6	2510	31.0	3200	HS012CE1
65	100	18	1.1	0.6	22.7	2320	29.4	3000	38.0	3900	HS013CE1
70	110	20	1.1	0.6	26.4	2700	35.0	3600	45.0	4600	HS014CE1
75	115	20	1.1	0.6	26.9	2750	36.5	3750	48.0	4900	HS015CE1*
80	125	22	1.1	0.6	35.0	3600	47.5	4850	61.5	6300	HS016CE1
85	130	22	1.1	0.6	35.5	3650	50.0	5100	64.5	6600	HS017CE1*
90	140	24	1.5	1.1	37.0	3800	53.5	5500	70.0	7150	HS018CE1*
95	145	24	1.5	1.1	46.0	4700	65.0	6650	83.5	8550	HS019CE1*
100	150	24	1.5	1.1	46.5	4750	68.0	6950	87.5	8950	HS020CE1

- ① Minimum allowable dimension for chamfer dimension r or r₁
- ② Bearings with * mark are not available and could be supplied on request
- ③ All limiting speeds of bearing already consider speed factor for contact angle f₃

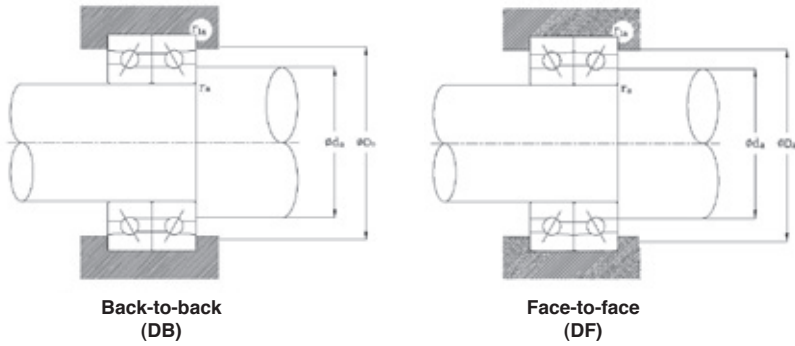

Static equivalent radial load $P_{or} = X_o F_r + Y_o F_a$

Contact Angle	Single DT		DB or DF	
	X_o	Y_o	X_o	Y_o
15	0.5	0.46	1	0.92
18	0.5	0.42	1	0.84
25	0.5	0.38	1	0.76
30	0.5	0.33	1	0.66
40	0.5	0.26	1	0.52

where P_{or} : Static equivalent radial load(N)

F_r : Radial load(N)

F_a : Axial load(N)

X_o : Static radial load factor

Y_o : Static axial load factor

Load Center (mm)	Limiting Speeds n_L (min ⁻¹) ^③		Reference Dimensions			Abutment and Dimensions (mm)					Space Capacity (cm ³)	Weight (kg)
	Grease	Oil	d_1	D_1	D_2	d_a min	D_a max	D_b max	r_a max	r_{la} max	Open (Approx)	Open (Approx)
7.0	77900	119800	16.3	19.8	22.5	14	12	12.6	0.3	0.15	0.5	0.019
7.2	65900	101400	18.3	21.8	24.9	16.5	24.5	25.1	0.3	0.15	0.6	0.021
8.0	53900	82900	21.6	25.6	28.5	19	29	30.5	0.3	0.15	0.9	0.028
9.0	47900	73700	24.1	28.1	31.8	21	32	32.6	0.3	0.15	1.3	0.035
11.0	40100	61700	28.6	33.6	37.7	25	37	38.2	0.6	0.3	2.2	0.065
12.0	33500	51600	33.6	38.6	42.7	30	42	43.2	0.6	0.3	2.5	0.078
13.0	35900	55300	38.7	46.3	49.2	34.6	50.4	52.4	1.0	0.6	3.9	0.11
15.0	29900	46100	44.2	52.8	56.0	39.6	57.4	59.4	1.0	0.6	4.8	0.15
16.0	27000	41500	49.7	58.2	61.6	44.6	63.4	65.4	1.0	0.6	5.9	0.19
18.0	24600	37800	55.7	64.2	67.6	49.6	70.4	72.4	1.0	0.6	8.1	0.24
19.0	22800	35000	60.2	69.8	73.4	54.6	75.4	77.4	1.0	0.6	8.8	0.25
21.0	19200	29500	67.7	77.3	81.0	61	84	86.2	1.1	0.6	12	0.40
21.5	18000	27600	72.7	82.3	86.0	66	89	91.2	1.1	0.6	13	0.42
22.5	16800	25800	77.3	87.7	91.8	71	94	96.2	1.1	0.6	14	0.45
24.5	15600	24000	84.3	95.3	100.1	76	104	106.2	1.1	0.6	20	0.64
25.5	14400	22100	89.3	100.7	105.1	81	109	111.2	1.1	0.6	20	0.67
28.0	12900	19900	95.8	109.2	114.3	86	119	121.2	1.1	0.6	27	0.85
28.5	12600	19400	100.8	114.2	119.3	91	124	126.2	1.1	0.6	28	0.90
31.0	11600	17900	108.3	121.7	126.9	97	113	116	1.5	1.1	37	1.20
31.5	11100	17100	112.4	127.6	133.4	102	138	141	1.5	1.1	38	1.25
32.0	10700	16500	117.4	132.6	138.4	107	143	146	1.5	1.1	40	1.30

Angular Contact Ball Bearings

70 A Series

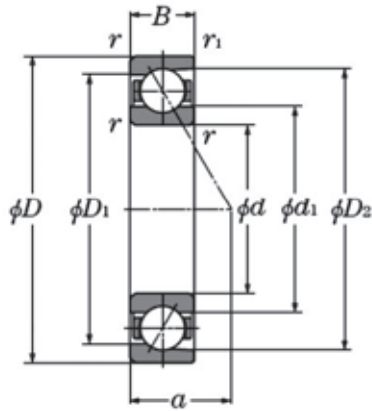

Dynamic equivalent radial load
 $P_r = X F_r + Y F_a$

Normal Contact Angle	$i f_0 F_a^*$ C_{or}	e	Single, DT				DB or DF				
			$F_r/F_a \leq e$		$F_r/F_a > e$		$F_r/F_a \leq e$		$F_r/F_a > e$		
			X	Y	X	Y	X	Y	X	Y	
15	0.178	0.38	1	0	0.44	1	1.47	1	1.65	0.72	2.39
	0.357	0.4					1.4		1.57		2.28
	0.714	0.43					1.3		1.46		2.11
	1.07	0.46					1.23		1.38		2
	1.43	0.47					1.19		1.34		1.93
	2.14	0.5					1.12		1.26		1.82
	3.57	0.55					1.02		1.14		1.66
	5.35	0.56					1		1.12		1.63
18	0.57		1	0	0.43	1	1	1.09	0.7	1.63	
25	0.68		1	0	0.41	0.87	1	0.92	1.67	1.41	
30	0.8		1	0	0.39	0.76	1	0.78	1.63	1.24	
40	1.14		1	0	0.35	0.57	1	0.55	0.57	0.93	
50	1.49				0.73	1	1.37	0.57	0.73		
55	1.79				0.81	1	1.6	0.56	0.81		
60	2.17				0.92	1	1.9	0.55	0.92		

For i, use 2 for DB, DF and 1 for DT
 where X: Radial load factor
 Y: Axial load factor

d 10~100mm

Boundary Dimensions (mm)					Basic Load Ratings				Static Axial Load Capacity		Bearing ^② Numbers Type
d	D	B	r ^① min	r_1 ^① min	Dynamic		Static		(KN)	(Kgf)	
					C_r (KN)	C_r (Kgf)	C_{or} (KN)	C_{or} (Kgf)			
6	17	6	0.3	0.15	2.03	269	0.80	81	0.73	74	706A
8	22	7	0.3	0.15	3.30	340	1.44	147	1.02	104	708A
10	26	8	0.3	0.15	5.00	510	2.33	238	2.00	204	7000A
12	28	8	0.3	0.15	5.05	515	2.46	251	2.38	243	7001A
15	32	9	0.3	0.15	5.75	590	3.10	320	2.90	296	7002A
17	35	10	0.3	0.15	6.05	620	3.50	360	3.40	350	7003A
20	42	12	0.6	0.3	10.3	1050	6.05	620	5.75	590	7004A
25	47	12	0.6	0.3	10.7	1100	6.15	630	6.35	650	7005A
30	55	13	1.0	0.6	13.9	1420	9.40	960	9.00	920	7006A
35	62	14	1.0	0.6	17.4	1780	12.5	1280	10.9	1120	7007A
40	68	15	1.0	0.6	18.1	1850	14.2	1450	12.7	1300	7008A
45	75	16	1.0	0.6	22.4	2290	18.6	1900	15.6	1600	7009A
50	80	16	1.0	0.6	23.6	2410	20.0	2040	17.8	1820	7010A*

- ① Minimum allowable dimension for chamfer dimension r or r₁
- ② Bearings with * mark are not available and could be supplied on request
- ③ All limiting speeds of bearing already consider speed factor for contact angle f₃

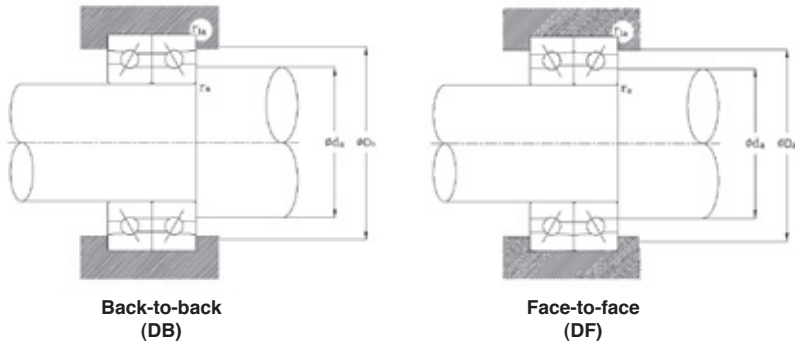

Static equivalent radial load $P_{or} = X_o F_r + Y_o F_a$

Contact Angle	Single DT		DB or DF	
	X_o	Y_o	X_o	Y_o
15	0.5	0.46	1	0.92
18	0.5	0.42	1	0.84
25	0.5	0.38	1	0.76
30	0.5	0.33	1	0.66
40	0.5	0.26	1	0.52

where P_{or} : Static equivalent radial load(N)
 F_r : Radial load(N)
 F_a : Axial load(N)
 X_o : Static radial load factor
 Y_o : Static axial load factor

Load Center (mm)	Limiting Speeds n_L (min ⁻¹) ^③		Reference Dimensions			Abutment and Dimensions (mm)					Space Capacity (cm ³)	Weight (kg)
	Grease	Oil	d_1	D_1	D_2	d_a min	D_a max	D_b max	r_a max	r_{1a} max	Open (Approx)	Open (Approx)
6.3	66000	87000	9.8	13.3	14.6	8.5	14.5	—	0.3	—	0.3	0.006
7.8	50000	67000	12.8	17.5	19.1	10.5	19.5	—	0.3	—	0.8	0.012
9.2	46600	60300	15.4	20.3	22.7	12.5	23.5	24.8	0.3	0.15	0.9	0.019
10	41900	54200	18.1	22.9	25.4	14.5	25.5	26.8	0.3	0.15	1.0	0.021
11.5	35700	46100	21.1	25.9	28.4	17.5	29.5	30.8	0.3	0.15	1.3	0.030
16	32300	41800	23.4	28.6	31	19.5	32.5	33.8	0.3	0.15	1.8	0.037
14.9	27000	35000	27.5	34.5	37.2	24.5	37.5	39.5	0.6	0.3	2.9	0.067
16.4	23300	30200	32.5	39.5	42.2	29.5	42.5	44.5	0.6	0.3	3.3	0.079
18.8	19800	25500	38.6	46.4	49.5	35.5	49.5	50.5	1.0	0.6	4.8	0.11
21.0	17400	22400	44.2	52.8	56.3	40.5	56.5	57.5	1.0	0.6	6.3	0.15
23.1	15500	20100	49.6	58.3	61.8	45.5	62.5	63.5	1.0	0.6	7.4	0.19
25.8	14000	18100	55.2	64.8	68.6	50.5	69.5	70.5	1.0	0.6	9.4	0.24
28.2	12900	16700	60.2	69.8	73.6	55.5	74.5	75.5	1.0	0.6	11	0.26

Angular Contact Ball Bearings

72A Series

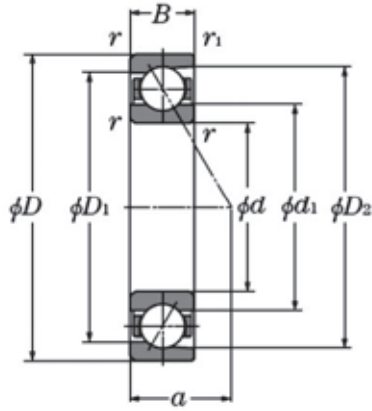

Dynamic equivalent radial load
 $P_r = X F_r + Y F_a$

Normal Contact Angle	$i f_0 F_a^*$ C_{or}	e	Single, DT				DB or DF									
			$F_r/F_a \leq e$		$F_r/F_a > e$		$F_r/F_a \leq e$		$F_r/F_a > e$							
			X	Y	X	Y	X	Y	X	Y						
15	0.178	0.38	1	0	0.44	1	1	1.47	1.65	0.72	2.39					
	0.357	0.4						1.4	1.57		2.28					
	0.714	0.43						1.3	1.46		2.11					
	1.07	0.46						1.23	1.38		2					
	1.43	0.47						1.19	1.34		1.93					
	2.14	0.5						1.12	1.26		1.82					
	3.57	0.55						1.02	1.14		1.66					
	5.35	0.56						1	1.12		1.63					
	18	0.57						1	0		0.43	1	1	1.09	0.7	1.63
	25	0.68						1	0		0.41	0.87	1	0.92	1.67	1.41
30	0.8	1	0	0.39	0.76	1	0.78	1.63	1.24							
40	1.14	1	0	0.35	0.57	1	0.55	0.57	0.93							
50	1.49			0.73	1	1.37	0.57	0.73								
55	1.79			0.81	1	1.6	0.56	0.81								
60	2.17			0.92	1	1.9	0.55	0.92								

For i, use 2 for DB, DF and 1 for DT
 where X: Radial load factor
 Y: Axial load factor

d 10~50mm

Boundary Dimensions (mm)					Basic Load Ratings				Static Axial Load Capacity		Bearing ^② Numbers Type
d	D	B	r ^①	r_1 ^①	Dynamic		Static		(KN)	(Kgf)	
			min	min	C_r (KN)	C_r (Kgf)	C_{or} (KN)	C_{or} (Kgf)			
10	30	9	0.6	0.3	5.05	515	2.45	250	1.92	196	7200A*
12	32	10	0.6	0.3	6.67	680	3.24	330	2.73	278	7201A
15	35	11	0.6	0.3	8.44	860	4.27	435	3.04	310	7202A
17	40	12	0.6	0.3	10.5	1070	5.40	550	4.07	415	7203A
20	47	14	1.0	0.6	13.6	1390	7.55	770	5.79	590	7204A
25	52	15	1.0	0.6	15.4	1570	9.47	965	6.97	710	7205A
30	62	16	1.0	0.6	21.3	2170	13.6	1390	9.22	940	7206A
35	72	17	1.1	0.6	28.2	2870	18.5	1890	12.8	1300	7207A
40	80	18	1.1	0.6	33.8	3450	20.7	2110	15.9	1620	7208A
45	85	19	1.1	0.6	37.8	3850	26.8	2730	18.1	1840	7209A*
50	90	20	1.1	0.6	39.7	4050	29.3	2990	19.4	1980	7210A*

① Minimum allowable dimension for chamfer dimension r or r₁
 ② Bearings with * mark are not available and could be supplied on request
 ③ All limiting speeds of bearing already consider speed factor for contact angle f₃

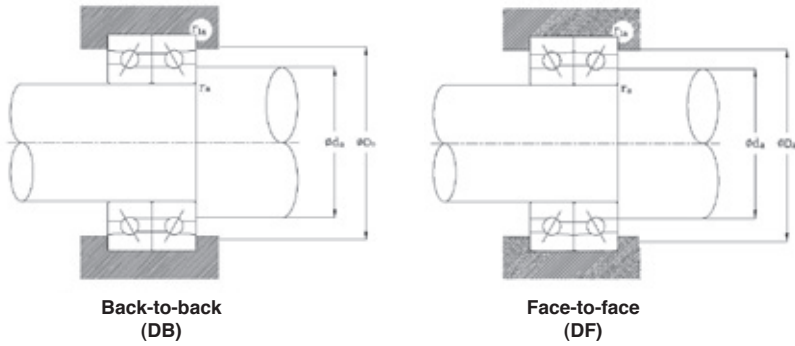

Static equivalent radial load $P_{or} = X_o F_r + Y_o F_a$

Contact Angle	Single DT		DB or DF	
	X_o	Y_o	X_o	Y_o
15	0.5	0.46	1	0.92
18	0.5	0.42	1	0.84
25	0.5	0.38	1	0.76
30	0.5	0.33	1	0.66
40	0.5	0.26	1	0.52

where P_{or} : Static equivalent radial load(N)
 F_r : Radial load(N)
 F_a : Axial load(N)
 X_o : Static radial load factor
 Y_o : Static axial load factor

Load Center (mm)	Limiting Speeds n_L (min ⁻¹) ^③		Reference Dimensions			Abutment and Dimensions (mm)					Space Capacity (cm ³)	Weight (kg)
	Grease	Oil	d_1	D_1	D_2	d_a min	D_a max	D_b max	r_a max	r_{1a} max	Open (Approx)	Open (Approx)
10.3	27700	36000	17.4	23.0	26.2	14.5	25.5	27.5	0.6	0.3	0.9	0.029
11.4	25800	33500	18.7	25.7	28.2	16.5	27.5	29.5	0.6	0.3	1.3	0.036
12.7	22700	29400	21.7	28.7	31.3	19.5	30.5	32.5	0.6	0.3	1.5	0.045
14.2	19700	25500	24.8	32.7	35.7	21.5	35.5	37.5	0.6	0.3	2.1	0.062
16.7	16400	21300	29.2	38.5	41.9	25.5	41.5	42.5	1.0	0.6	3.1	0.10
18.6	14600	18800	34.2	43.5	47.0	30.5	46.5	47.5	1.0	0.6	4.1	0.12
21.3	12200	15800	40.8	52.0	56.0	35.5	56.5	57.5	1.0	0.6	6.6	0.19
23.9	10600	13700	47.4	60.5	65.2	42.0	65.0	67.5	1.0	0.6	8.8	0.27
26.3	9480	12300	53.5	67.5	72.4	47.0	73.0	75.5	1.0	0.6	11	0.35
28.4	8700	11300	58.1	73.0	78.4	52.0	78.0	80.5	1.0	0.6	14	0.40
30.2	8120	10500	63.1	78.0	82.5	57.0	83.0	85.5	1.0	0.6	17	0.45

Angular Contact Ball Bearings

BS Series

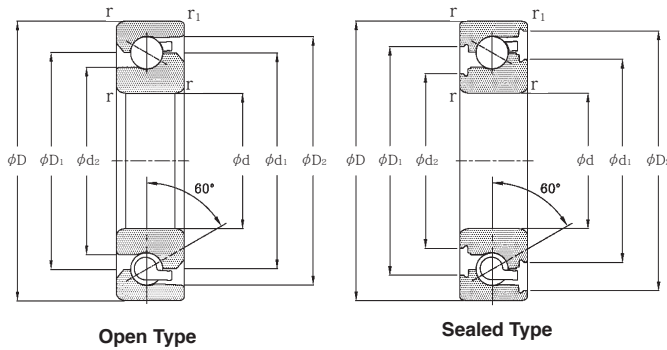

Dynamic equivalent radial load
 $P_r = X F_r + Y F_a$

Normal Contact Angle	$i f_0 F_a^*$ C_{or}	e	Single, DT				DB or DF				
			$F_r/F_a \leq e$		$F_r/F_a > e$		$F_r/F_a \leq e$		$F_r/F_a > e$		
			X	Y	X	Y	X	Y	X	Y	
15	0.178	0.38				1.47		1.65		2.39	
	0.357	0.4				1.4		1.57		2.28	
	0.714	0.43				1.3		1.46		2.11	
	1.07	0.46				1.23		1.38		2	
	1.43	0.47	1	0	0.44	1.19	1	0.34	0.72	1.93	
	2.14	0.5				1.12		0.26		1.82	
	3.57	0.55				1.02		1.14		1.66	
	5.35	0.56				1		1.12		1.63	
18	0.57			1	0	0.43	1	1	1.09	0.7	1.63
25	0.68			1	0	0.41	0.87	1	0.92	1.67	1.41
30	0.8			1	0	0.39	0.76	1	0.78	1.63	1.24
40	1.14			1	0	0.35	0.57	1	0.55	0.57	0.93
50	1.49					0.73	1	1.37	0.57	0.73	
55	1.79					0.81	1	1.6	0.56	0.81	
60	2.17					0.92	1	1.9	0.55	0.92	

For i, use 2 for DB, DF and 1 for DT
 where X: Radial load factor
 Y: Axial load factor

Boundary Dimensions (mm)					Basic Load Ratings				Static Axial Load Capacity		Bearing ^② Numbers Type
d	D	B	r ^① min	r_1 ^① min	Dynamic		Static		(KN)	(Kgf)	
					C_a (KN)	C_a (Kgf)	C_{oa} (KN)	C_{oa} (Kgf)			
17	47	15	1.0	0.6	24.2	2470	37.5	3850	25.7	2620	BS1747LLB BS1747
20	47	15	1.0	0.6	24.2	2470	37.5	3850	25.7	2620	BS2047LLB BS2047
25	62	15	1.0	0.6	29.2	2980	59.0	6050	40.0	4100	BS2562LLB BS2562
30	62	15	1.0	0.6	29.2	2980	59.0	6050	40.0	4100	BS3062LLB BS3062
35	72	15	1.0	0.6	30.5	3150	70.0	7150	47.5	4850	BS3572LLB BS3572
40	72	15	1.0	0.6	30.5	3150	70.0	7150	47.5	4850	BS4072LLB BS4072
45	75	15	1.0	0.6	32.0	3300	77.0	7900	52.0	5350	BS4575LLB BS4575
40	90	20	1.0	0.6	58.5	6000	130	13300	88.0	9000	BS4090LLB BS4090
45	100	20	1.0	0.6	62.0	6350	153	15600	104	10600	BS45100
50	100	20	1.0	0.6	62.0	6350	153	15600	104	10600	BS50100LLB BS50100
60	120	20	1.0	0.6	66.0	6750	183	18700	124	12700	BS60120LLB BS60120

- ① Minimum allowable dimension for chamfer dimension r or r_1
- ② Bearings with * mark are not available and could be supplied on request
- ③ All limiting speeds of bearing already consider speed factor for contact angle f_3

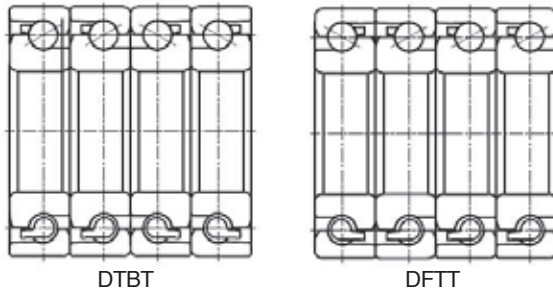
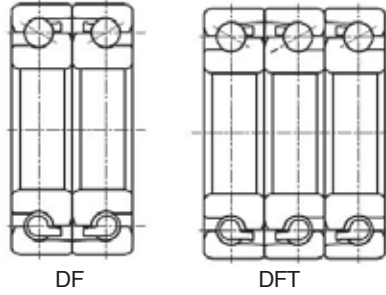

Static equivalent radial load $P_{0r} = X_0 F_r + Y_0 F_a$

Contact Angle	Single	
	X_0	Y_0
60	3.98	1

Static equivalent axial load $P_{0a} = 3.98 F_r + F_a$

where P_{0a} : Static equivalent axial load(N)
 F_r : Radial load(N)
 F_a : Axial load(N)

Limiting Speeds n_L (min ⁻¹) ^③		Reference Dimensions				Space Capacity (cm ³)	Weight (kg)
Grease	Oil	d_1	d_2	D_1	D_2	Open (Approx)	Open (Approx)
10300	13700	33.4	27.1	35.9 33.7	42.5 40.2	3.3	0.129
10300	13700	33.4	27.1	35.9 33.7	42.5 40.2	3.3	0.118
7200	9600	47.9	41.6	50.4 48.2	57.3 55.2	4.6	0.231
7200	9600	47.9	41.6	50.4 48.2	57.3 55.2	4.6	0.205
6500	8600	55.8	49.5	58.5 56.3	65.0 63.2	5.4	0.284
6500	8600	55.8	49.5	58.5 56.3	65.0 63.2	5.4	0.250
5500	7400	62.2	55.6	64.4 62.2	70.9 69.1	6.0	0.254
5100	6800	68.0	57.0	70.2 68.0	82.1 80.3	12	0.636
4400	6200	78.9	69.2	79.2	90.6	13	0.842
4400	5800	78.9	69.2	81.2 79.2	91.9 90.6	13	0.778
3700	4400	93.2	83.8	95.6 93.4	106.8 105.2	16	1.16

Angular Contact Ball Bearings

Special Series

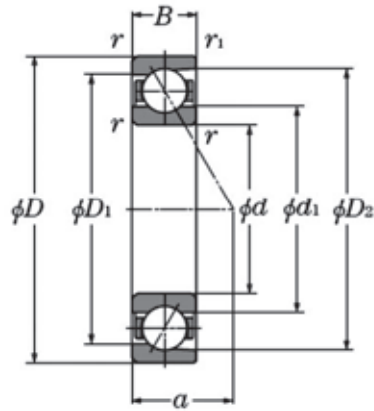

Dynamic equivalent radial load
 $P_r = X F_r + Y F_a$

Normal Contact Angle	$i f_0 F_a^*$ C_{or}	e	Single, DT				DB or DF				
			$F_r/F_r \leq e$		$F_r/F_r > e$		$F_r/F_r \leq e$		$F_r/F_r > e$		
			X	Y	X	Y	X	Y	X	Y	
15	0.178	0.38	1	0	0.44	1	1	1.47	1.65	0.72	2.39
	0.357	0.4						1.4	1.57		2.28
	0.714	0.43						1.3	1.46		2.11
	1.07	0.46						1.23	1.38		2
	1.43	0.47						1.19	1.34		1.93
	2.14	0.5						1.12	1.26		1.82
	3.57	0.55						1.02	1.14		1.66
	5.35	0.56						1	1.12		1.63
18	0.57	1	0	0.43	1	1	1.09	0.7	1.63		
25	0.68	1	0	0.41	0.87	1	0.92	1.67	1.41		
30	0.8	1	0	0.39	0.76	1	0.78	1.63	1.24		
40	1.14	1	0	0.35	0.57	1	0.55	0.57	0.93		
50	1.49			0.73	1	1.37	0.57	0.73			
55	1.79			0.81	1	1.6	0.56	0.81			
60	2.17			0.92	1	1.9	0.55	0.92			

For i, use 2 for DB, DF and 1 for DT
 where X: Radial load factor
 Y: Axial load factor

d 8~100mm

Boundary Dimensions (mm)					Basic Load Ratings				Static Axial Load Capacity		Bearing Numbers Type
d	D	B	r ①	r_1 ①	Dynamic		Static		(KN)	(Kgf)	
			min	min	C_r (KN)	C_r (Kgf)	C_{or} (KN)	C_{or} (Kgf)			
8	22	10.31	0.3	0.15	3.50	360	1.54	157	1.41	144	5S1-SF8AT01C
17	30	8	0.3	0.15	6.20	635	6.30	645	6.75	690	5S1-SF03T01C
35	72	17	1.1	0.6	29.1	2970	19.1	1950	15.5	1580	7207AD
40	80	18	1.1	0.6	34.5	3500	24.0	2450	22.1	2260	7208AD
50	90	20	1.1	0.6	40.5	4150	30.0	3050	23.5	2400	7210AD
70	110	20	1.1	0.6	32.0	3250	33.5	3400	70.5	7200	HS014AD
100	150	45	1.5	1.0	58.5	6000	134	13700	82.0	8400	BT020A DB
100	150	45	1.5	1.0	72.0	7300	158	16200	80.0	8200	BT020B DB

① Minimum allowable dimension for chamfer dimension r or r_1

② All limiting speeds of bearing already consider speed factor for contact angle f_3

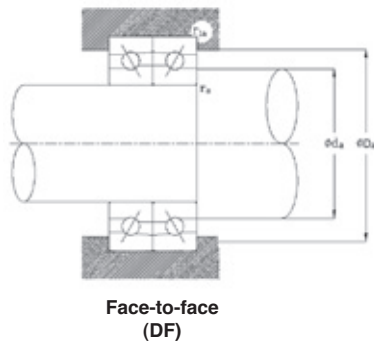
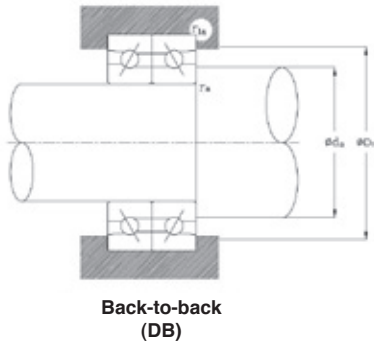

Static equivalent radial load $P_{or} = X_o F_r + Y_o F_a$

Contact Angle	Single DT		DB or DF	
	X_o	Y_o	X_o	Y_o
15	0.5	0.46	1	0.92
18	0.5	0.42	1	0.84
25	0.5	0.38	1	0.76
30	0.5	0.33	1	0.66
40	0.5	0.26	1	0.52

where P_{or} : Static equivalent radial load(N)
 F_r : Radial load(N)
 F_a : Axial load(N)
 X_o : Static radial load factor
 Y_o : Static axial load factor

Load Center (mm)	Limiting Speeds n_L (min^{-1}) ^②		Reference Dimensions (mm)			Abutment and Dimensions (mm)					Space Capacity (cm^3)	Weight (kg)
	Grease	Oil	d_1	D_1	D_2	d_a min	D_a max	D_b max	r_a max	r_{1a} max	Open (Approx)	Open (Approx)
a												
7.2	92400	140400	12.8	17.5	19.2	10.5	19.5	—	0.3	—	0.8	0.015
7.0	38000	51000	21.1	25.9	28.4	19.5	27.5	28.8	0.3	0.15	1.3	0.025
18.5	14100	18300	46.8	60.2	64.57	42	65	67.5	1.0	0.6	8.8	0.28
20.5	12600	16300	53	67.1	71.7	47	73	75.5	1.0	0.6	11	0.35
23.3	10800	14000	63.1	78	82.5	57	83	85.5	1.0	0.6	17	0.45
30.8	13400	18900	84.3	95.3	99.3	76	104	106.2	1.1	0.6	20	0.64
74.9	5300	6600	118.2	131.6	137.9	108.5	141.5	144.5	1.5	1.0	81	2.62
58.6	4600	5700	118.7	131.3	137.3	108.5	141.5	144.5	1.5	1.0	81	2.01

Cylindrical Roller Bearings

NN Series

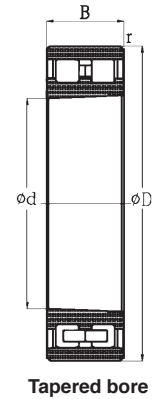

d 30~130mm

Boundary Dimensions (mm)				Basic Load Ratings				Circumscribed circle diameter of roller (mm)	Bearing Numbers Type ^②
d	D	B	r ^① min	Dynamic		Static			
				C_r (KN)	C_r (Kgf)	C_{or} (KN)	C_{or} (Kgf)		
30	55	19	1.0	31.0	3150	37.0	3800	48.5	NN3006K
80	125	34	1.1	118	12000	182	18600	113	NN3016K*
90	140	37	1.5	146	14900	232	23600	127	NN3018K
100	150	37	1.5	156	15900	261	26600	137	NN3020K
110	170	45	2.0	234	23900	382	38900	155	NN3022K*
120	180	46	2.0	238	24300	400	40800	165	NN3024K*
130	200	52	2.0	291	29700	486	49500	182	NN3026K*

① Minimum allowable dimension for chamfer dimension r or r_1

② Bearings with * mark are not available and could be supplied on request

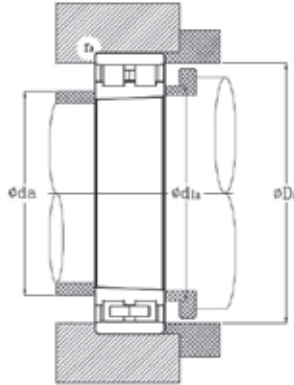

Dynamic equivalent radial load
 $P_r = F_r$
 Static equivalent radial load
 $P_{or} = F_r$

Limiting Speeds n_L (min^{-1})		Abutment and Dimensions (mm)					Space Capacity (cm^3)	Weight (kg)
Grease	Oil	d_a min	d_{1a} min	D_a		r_a max	Open (Approx)	Open (Approx)
				(Max)	(Min)			
16300	19800	35	36	50	50	1.0	6.3	0.19
6800	8300	86.5	87	118.5	115	1.0	45	1.47
6000	7300	98	99	132	129	1.5	64.1	2.01
5600	6700	108	109	142	139	1.5	67.5	2.19
5000	6000	119	121	161	157	2.0	115	3.56
4600	5600	129	131	171	167	2.0	130	3.83
4200	5100	139	141	191	185	2.0	182	5.71

Appendix I: Required Information for Spindle Bearings Selection

(1) Machine Type	<input type="checkbox"/> NC Lathe <input type="checkbox"/> Machine center <input type="checkbox"/> Grinding Machine <input type="checkbox"/> Others_____
(2) Main spindle orientation	<input type="checkbox"/> Vertical <input type="checkbox"/> Horizontal <input type="checkbox"/> Variable-direction <input type="checkbox"/> Inclined <input type="checkbox"/> Others_____
(3) Diameter of main spindle	<input type="checkbox"/> #30 <input type="checkbox"/> #40 <input type="checkbox"/> #50 <input type="checkbox"/> Others_____
(4) Duplex arrangement of bearing	[DB 、 DBT 、 DF 、 DFT 、 DT 、 DTBT 、 DTFT 、 other ()]
(5) Intended bearing type, dimension and preload method	Front: <input type="checkbox"/> Cylindrical roller type <input type="checkbox"/> Angular contact type [** <input type="checkbox"/> sealing] Rear: <input type="checkbox"/> Cylindrical roller type <input type="checkbox"/> Angular contact type [** <input type="checkbox"/> sealing] Preloading system: <input type="checkbox"/> Fixed-position <input type="checkbox"/> Fixed-pressure
(6) Slide system free side	<input type="checkbox"/> Cylindrical roller bearing <input type="checkbox"/> Ball bushing (availability of cooling)
(7) Lubrication method	<input type="checkbox"/> Grease <input type="checkbox"/> Air-oil <input type="checkbox"/> Oil mist
(8) Drive system	<input type="checkbox"/> built-in motor <input type="checkbox"/> Belt drive <input type="checkbox"/> Coupling
(9) Presence/absence of jacket cooling arrangement on bearings area	<input type="checkbox"/> YES <input type="checkbox"/> NO
(10) Load conditions (machining conditions)	Max. speed: _____ Min ⁻¹ Radial load Fr: _____ N Axial load Fa: _____ N Moment: _____ N-mm Tightening force: _____ N
(11) Shaft and Housing	Shaft material: _____ Shaft tolerance: _____ mm Housing material: _____ Housing tolerance: _____ mm Housing outer diameter: _____ mm Hollow shaft bore diameter: _____ mm Fits on shaft : _____ mm Fits on housing : _____ mm Spacer length: _____ mm Ambient temperature: _____ °C
(12) Requirement Value	Rigidity: _____ N/um Preload: _____ N Life: _____ hours
(13) Specific Request	

Appendix II: Required Information for Ball Screw Support Bearings Selection

(1) Ball Screw Support Type	<input type="checkbox"/> Two-ends support <input type="checkbox"/> One-end support <input type="checkbox"/> Pretension
(2) Ball Screw Support Bearing	Installation type: <input type="checkbox"/> Fixed-Support <input type="checkbox"/> Fixed-Free <input type="checkbox"/> Fixed-Fixed Fixed-end bearing: <input type="checkbox"/> ACBB Support-end bearing: <input type="checkbox"/> ACBB <input type="checkbox"/> DGBB <input type="checkbox"/> NRB Fixed-end arrangement: <input type="checkbox"/> DB/DF <input type="checkbox"/> DBT/DFT <input type="checkbox"/> DTBT/DTFT Support-end arrangement: <input type="checkbox"/> Single <input type="checkbox"/> DB/DF <input type="checkbox"/> Others
(3) Lubrication method	<input type="checkbox"/> Grease <input type="checkbox"/> Air-oil
(4) Load conditions (machining conditions)	Max. speed: _____ Min^{-1} Radial load Fr: _____ N Axial load Fa: _____ N Moment: _____ N-mm Tightening force: _____ N
(5) Shaft and Housing	Shaft material: _____ Shaft tolerance: _____ mm Housing material: _____ Housing tolerance: _____ mm Housing outer diameter: _____ mm Hollow shaft bore diameter: _____ mm Fits on shaft : _____ mm Fits on housing : _____ mm Spacer length: _____ mm Ambient temperature: _____ °C
(6) Requirement Value	Rigidity: _____ N/um Preload: _____ N Starting Torque: _____ N-mm Life: _____ hours
(7) Specific Requests	

Appendix III : Tolerance for Rolling Bearings

1.Radial Bearing(Angular Contact Ball Bearings)

Inner rings

Unit : μm

Nominal bore diameter		Single plane mean bore diameter deviation						Single radial plane bore diameter variation						Mean bore diameter deviation			Inner ring radial runout		
d		Δ_{dmp}						V_{dp}						V_{dmp}			K_{ia}		
mm		Class 5		Class 4 ^①		Class 2 ^①		Diameter series 9			Diameter series 0.2			Class 5 Class 4 Class 2			Class 5 Class 4 Class 2		
over	incl.	high	low	high	low	high	low	Class 5	Class 4	Class 2	Class 5	Class 4	Class 2	Class 5	Class 4	Class 2	Class 5	Class 4	Class 2
								max			max			max			max		
2.5	10	0	-5	0	-4	0	-2.5	5	4	2.5	4	3	2.5	3	2	1.5	4	2.5	1.5
10	18	0	-5	0	-4	0	-2.5	5	4	2.5	4	3	2.5	3	2	1.5	4	2.5	1.5
18	30	0	-6	0	-5	0	-2.5	6	5	2.5	5	4	2.5	3	2.5	1.5	4	3	2.5
30	50	0	-8	0	-6	0	-2.5	8	6	2.5	6	5	2.5	4	3	1.5	5	4	2.5
50	80	0	-9	0	-7	0	-4	9	7	4	7	5	4	5	3.5	2	5	4	2.5
80	120	0	-10	0	-8	0	-5	10	8	5	8	6	5	5	4	2.5	6	5	2.5
120	150	0	-13	0	-10	0	-7	13	10	7	10	8	7	7	5	3.5	8	6	2.5
150	180	0	-13	0	-10	0	-7	13	10	7	10	8	7	7	5	3.5	8	6	5
180	250	0	-15	0	-12	0	-8	15	12	8	12	9	8	8	6	4	10	8	5

① The tolerance of bore diameter deviation Δds , applicable to classes 4 and 2, is the same as the tolerance of mean bore diameter deviation Δdmp . This applies to the diameter series 0 or 2 for class 4, and all the diameter series for class 2.

② Applicable to individual bearing rings manufactured for duplex bearings.

Outer rings

Unit : μm

Nominal outside diameter		Single plane mean outside diameter deviation						Single radial plane outside diameter variation						Mean single plane outside diameter variation			Outer ring radial runout		
D		Δ_{Dmp}						V_{Dp}						V_{Dmp}			K_{eo}		
mm		Class 5		Class 4 ^③		Class 2 ^③		Diameter series 9			Diameter series 0.2			Class 5 Class 4 Class 2			Class 5 Class 4 Class 2		
over	incl.	high	low	high	low	high	low	Class 5	Class 4	Class 2	Class 5	Class 4	Class 2	Class 5	Class 4	Class 2	Class 5	Class 4	Class 2
								max			max			max			max		
18	30	0	-6	0	-5	0	-4	6	5	4	5	4	4	3	2.5	2	6	4	2.5
30	50	0	-7	0	-6	0	-4	7	6	4	5	5	4	4	3	2	7	5	2.5
50	80	0	-9	0	-7	0	-4	9	7	4	7	5	4	5	3.5	2	8	5	4
80	120	0	-10	0	-8	0	-5	10	8	5	8	6	5	5	4	2.5	10	6	5
120	150	0	-11	0	-9	0	-5	11	9	5	8	7	5	6	5	2.5	11	7	5
150	180	0	-13	0	-10	0	-7	13	10	7	10	8	7	7	5	3.5	13	8	5
180	250	0	-15	0	-11	0	-8	15	11	8	11	8	8	8	6	4	15	10	7
250	315	0	-18	0	-13	0	-8	18	13	8	14	10	8	9	7	4	18	11	7

③ The tolerance of outside diameter deviation ΔDs , applicable to classes 4 and 2, is the same as the tolerance of mean outside diameter deviation ΔDmp . This applies to the diameter series 0 or 2 for class 4, and all the diameter series for class 2.

Inner rings

 Unit : μm

Face runout with bore S_d			Axial runout S_{av}			Width deviation Δ_{Bs}						Width variation V_{Bs}		
Class 5	Class 4	Class 2	Class 5	Class 4	Class 2	Single bearing				Duplex bearing ②		Class 5	Class 4	Class 2
						Class 5	Class 4	Class 2		Class 5	Class 4			
max			max			high	low	high	low	high	low	max		
7	3	1.5	7	3	1.5	0	-40	0	-40	0	-250	5	2.5	1.5
7	3	1.5	7	3	1.5	0	-80	0	-80	0	-250	5	2.5	1.5
8	4	1.5	8	4	2.5	0	-120	0	-120	0	-250	5	2.5	1.5
8	4	1.5	8	4	2.5	0	-120	0	-120	0	-250	5	3	1.5
8	5	1.5	8	5	2.5	0	-150	0	-150	0	-250	6	4	1.5
9	5	2.5	9	5	2.5	0	-200	0	-200	0	-380	7	4	2.5
10	6	2.5	10	7	2.5	0	-250	0	-250	0	-380	8	5	2.5
10	6	4	10	7	5	0	-250	0	-250	0	-380	8	5	4
11	7	5	13	8	5	0	-300	0	-300	0	-500	10	6	5

Outer rings

 Unit : μm

Outside surface inclination S_D			Axial runout S_{av}			Width deviation Δ_{Cs}			Width variation V_{Cs}		
Class 5	Class 4	Class 2	Class 5	Class 4	Class 2	All types			Class 5	Class 4	Class 2
						Class 5	Class 4	Class 2			
max			max						max		
8	4	1.5	8	5	2.5	Identical to of Δ_{Bs}			5	2.5	1.5
8	4	1.5	8	5	2.5	relative to d of the same bearing.			5	2.5	1.5
8	4	1.5	10	5	4				6	3	1.5
9	5	2.5	11	6	5				8	4	2.5
10	5	2.5	13	7	5	8	5	2.5			
10	5	2.5	14	8	5	8	5	2.5			
11	7	4	15	10	7	10	7	4			
13	8	5	18	10	7	11	7	5			

2. Ball Screw Support Bearings

Inner rings

Unit : μm

Nominal bore diameter d		Single plane mean bore diameter deviation Δ_{dmp}						Width variation V_B			Radial runout K_{ra}			Face runout with bore S_d			Axial runout S_a			Width deviation Δ_B					
mm		Class 5		Class 4 Φ		Class UP Φ		Class 5	Class 4	Class UP	Class 5	Class 4	Class UP	Class 5	Class 4	Class UP	Class 5	Class 4	Class UP	Class 5		Class 4		Class UP	
over	incl.	high	low	high	low	high	low	max			max			max			max			high	low	high	low	high	low
10	18	0	-5	0	-4	0	-3.5	5	2.5	2	3.5	3	2	7	3	2	5	3	2	0	-120	0	-120	0	-100
18	30	0	-6	0	-5	0	-3.5	5	2.5	2	4	3	2	8	4	3	5	3	2	0	-120	0	-120	0	-100
30	50	0	-8	0	-6	0	-5	5	3	2	5	4	3	8	4	3	6	3	2	0	-120	0	-120	0	-100
50	80	0	-9	0	-7	0	-5	6	4	3	5	4	4	8	5	4	7	4	3	0	-150	0	-150	0	-150

① The tolerance of outside diameter deviation Δds applicable to classes 4 and UP is the same as the tolerance of single plane mean outside diameter deviation Δdmp .

Outer rings

Unit : μm

Nominal bore diameter D		Single plane mean outside diameter deviation Δ_{Dmp}						Width variation V_G			Radial runout K_{ra}			Outside surface inclination S_D			Axial runout S_a			Width deviation Δ_G							
mm		Class 5		Class 4 Φ		Class UP Φ		Class 5	Class 4	Class UP	Class 5	Class 4	Class UP	Class 5	Class 4	Class UP	All classes			All classes							
over	incl.	high	low	high	low	high	low	max			max			max						high		low		high		low	
30	50	0	-7	0	-6	0	-5	5	2.5	2	7	5	4	8	4	3	Identical to S_{ia} relative to d on the same bearing.			Identical to ΔBs relative to d on the same bearing.							
50	80	0	-9	0	-7	0	-5	6	3	2	8	5	4	8	4	3											
80	120	0	-10	0	-8	0	-7	8	4	3	10	6	4	9	5	4											

② The tolerance of outside diameter deviation ΔDs applicable to classes 4 and UP is the same as the tolerance of single plane mean outside diameter deviation ΔDmp .

3. Cylindrical Roller Bearings

Inner rings

 Unit : μm

Nominal bore diameter		Single plane mean bore diameter deviation Δ_{dmp}						Single radial plane bore diameter variation V_{Dp}						Mean bore diameter deviation V_{Dmp}			Inner ring radial runout K_{ri}					
d		Class 5		Class 4 ^①		Class 2 ^①		Diameter series 9			Diameter series 0			Class 5			Class 4			Class 2		
over	incl.	high	low	high	low	high	low	Class 5 max	Class 4	Class 2	Class 5 max	Class 4	Class 2	Class 5 max	Class 4	Class 2	Class 5 max	Class 4	Class 2	Class 5 max	Class 4	Class 2
18	30	0	-6	0	-5	0	-2.5	6	5	2.5	5	4	2.5	3	2.5	1.5	4	3	2.5	4	3	2.5
30	50	0	-8	0	-6	0	-2.5	8	6	2.5	6	5	2.5	4	3	1.5	5	4	2.5	5	4	2.5
50	80	0	-9	0	-7	0	-4	9	7	4	7	5	4	5	3.5	2	5	4	2.5	5	4	2.5
80	120	0	-10	0	-8	0	-5	10	8	5	8	6	5	5	4	2.5	6	5	2.5	6	5	2.5
120	150	0	-13	0	-10	0	-7	13	10	7	10	8	7	7	5	3.5	8	6	2.5	8	6	2.5
150	180	0	-13	0	-10	0	-7	13	10	7	10	8	7	7	5	3.5	8	6	5	8	6	5
180	250	0	-15	0	-12	0	-8	15	12	8	12	9	8	8	6	4	10	8	5	10	8	5
250	315	0	-18	-	-	-	-	18	-	-	14	-	-	9	-	-	13	-	-	13	-	-
315	400	0	-23	-	-	-	-	23	-	-	18	-	-	12	-	-	15	-	-	15	-	-
400	500	-	-	-	-	-	-	-	-	-	-	-	-	-	-	-	-	-	-	-	-	-

① The tolerance of bore diameter deviation Δd_s applicable to classes 4 and 2 is the same as the tolerance of single plane mean bore diameter deviation Δd_{mp} .

Outer rings

 Unit : μm

Nominal bore diameter		Single plane mean outside diameter deviation Δ_{Dmp}						Single radial plane outside diameter variation V_{Dp}						Mean single plane outside diameter variation V_{Dmp}			Outer ring radial runout K_{ro}					
D		Class 5		Class 4 ^②		Class 2 ^②		Diameter series 9			Diameter series 0			Class 5			Class 4			Class 2		
over	incl.	high	low	high	low	high	low	Class 5 max	Class 4	Class 2	Class 5 max	Class 4	Class 2	Class 5 max	Class 4	Class 2	Class 5 max	Class 4	Class 2	Class 5 max	Class 4	Class 2
30	50	0	-7	0	-6	0	-4	7	6	4	5	5	4	4	3	2	7	5	2.5	7	5	2.5
50	80	0	-9	0	-7	0	-4	9	7	4	7	5	4	5	3.5	2	8	5	4	8	5	4
80	120	0	-10	0	-8	0	-5	10	8	5	8	6	5	5	4	2.5	10	6	5	10	6	5
120	150	0	-11	0	-9	0	-5	11	9	5	8	7	5	6	5	2.5	11	7	5	11	7	5
150	180	0	-13	0	-10	0	-7	13	10	7	10	8	7	7	5	3.5	13	8	5	13	8	5
180	250	0	-15	0	-11	0	-8	15	11	8	11	8	8	8	6	4	15	10	7	15	10	7
250	315	0	-18	0	-13	0	-8	18	13	8	14	10	8	9	7	4	18	11	7	18	11	7
315	400	0	-20	0	-15	0	-10	20	15	10	15	11	10	10	8	5	20	13	8	20	13	8
400	500	0	-23	-	-	-	-	23	-	-	17	-	-	12	-	-	23	-	-	23	-	-
500	630	0	-28	-	-	-	-	28	-	-	21	-	-	14	-	-	25	-	-	25	-	-
630	800	0	-35	-	-	-	-	35	-	-	26	-	-	18	-	-	30	-	-	30	-	-

② The tolerance of outside diameter deviation Δs applicable to classes 4 and 2 is the same as the tolerance of mean single plane outside diameter deviation ΔD_{mp} .

Inner rings

Unit : μm

Face runout with bore S_d			Width deviation Δ_{Bs} Single bearing				Width variation V_{Bs}		
Class 5	Class 4 max	Class 2	Class 5 high	Class 4 low	Class 2 high	Class 2 low	Class 5	Class 4 max	Class 2
8	4	1.5	0	-120	0	-120	5	2.5	1.5
8	4	1.5	0	-120	0	-120	5	3	1.5
8	5	1.5	0	-150	0	-150	6	4	1.5
9	5	2.5	0	-200	0	-200	7	4	2.5
10	6	2.5	0	-250	0	-250	8	5	2.5
10	6	4	0	-250	0	-300	8	5	4
11	7	5	0	-300	0	-350	10	6	5
13	-	-	0	-350	-	-	13	-	-
15	-	-	0	-400	-	-	15	-	-
-	-	-	0	-	-	-	-	-	-

Outer rings

Unit : μm

Outside surface inclination S_D			Width deviation Δ_{Cs}	Width variation V_{Cs}		
Class 5	Class 4 max	Class 2	All classes	Class 5	Class 4 max	Class 2
8	4	1.5	Identical to Δ_{Bs} relative to d on the same bearing.	5	2.5	1.5
8	4	1.5		6	3	1.5
9	5	2.5		8	4	2.5
10	5	2.5		8	5	2.5
10	5	2.5		8	5	2.5
11	7	4		10	7	4
13	8	5		11	7	5
13	10	7		13	8	7
15	-	-		15	-	-
18	-	-		18	-	-
20	-	-		20	-	-

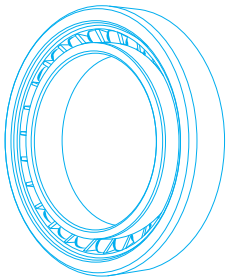

PRECISION ROLLING BEARINGS

TPI[®]
BEARINGS

TUNG PEI INDUSTRIAL CO.. LTD.

Taipei Head Office

10F., No. 142, Sec. 4, Zhongxiao E. Rd., Taipei City 106, Taiwan

TEL +886-2-2741-7321 FAX +886-2-2741-6623

SHANGHAI TUNGPEI ENTERPRISE CO.. LTD.

Shanghai Plant

No.1555, Rongle Rd.(E), Songjiang Industrial Zone, Shanghai, China

TEL +86-21-5774-4698 FAX +86-21-5774-4695

PT. TPI MANUFACTURING INDONESIA

Indonesia Plant

Kawasan GILC Blok AB No. 02, Kota Delta Mas, Desa Sukamahi Cikarang Pusat,
Bekasi 17530, Jawa Barat, Indonesia TEL + 62-21-8067-7410

Although care has been taken to assure the accuracy of the data compiled in this catalog, TPI does not assume any liability to any company or person for errors or omissions.

www.tpi.tw

